



K19-2031-0 Defender rear bumper installation

REMOVE CONTENTS FROM BOX. VERIFY ALL PARTS ARE PRESENT. READ INSTRUCTIONS CAREFULLY BEFORE STARTING INSTALLATION. ASSISTANCE IS RECOMMENDED.

Step 1-

- Start installation at the driver/left side of the vehicle. Locate the mounting holes in the frame under the bed

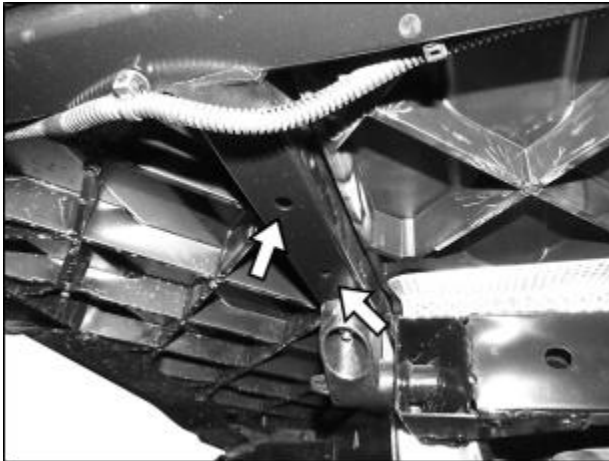

- Use an electric drill and 7/16" drill bit, (not included) to drill out the (2) mounting holes in the bottom of the square tube frame, **(Figure 1)**. **VERY IMPORTANT:** Only drill through the outer surface to enlarge the holes for a Threaded Insert, **do not drill completely through the frame and into the bed.**
 - Select the 8mm Threaded Insert Installation Tool and (1) 8mm Threaded Insert, **(Figure 2-A)**.
 - Screw the Insert onto the threaded end of the Insert Tool, **(Figure 2-A)**.
 - Firmly hold the Tool and push the Insert into one of the previously drilled holes, **(Figure 2-B)**.
 - Insert should fit snug into the drilled hole. Lightly tap the Tool and Insert into the hole with a small hammer if necessary.
 - Firmly hold the hex nut on the Insert Tool in place with a wrench and turn the hex bolt clockwise to tighten the bolt and expand the Insert in the hole **(Figure 2-C)**.
 - Once Insert is fully compressed and expanded, remove the Tool from the Insert, **(Figure 3)**. **WARNING:** Do not overtighten Insert or damage to the Insert may result.
 - Repeat the previous Steps to install the remaining (1) Threaded Insert.

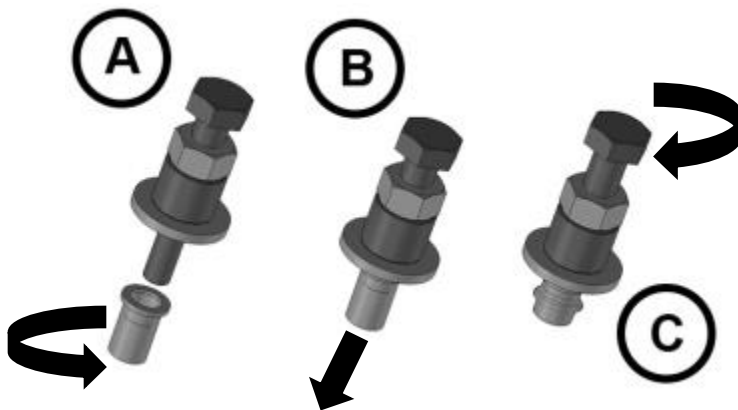

- Select the driver/left Mounting Bracket, (**Figure 4**). Slide the Bracket over the square tube frame. Attach the Mounting Bracket to the inner facing side of the frame with the included (2) 6mm x 60mm Hex Bolts, (4) 6mm Flat Washers and (2) 6mm Nylon Lock Nuts, (**Figures 4 & 5**). Leave loose.

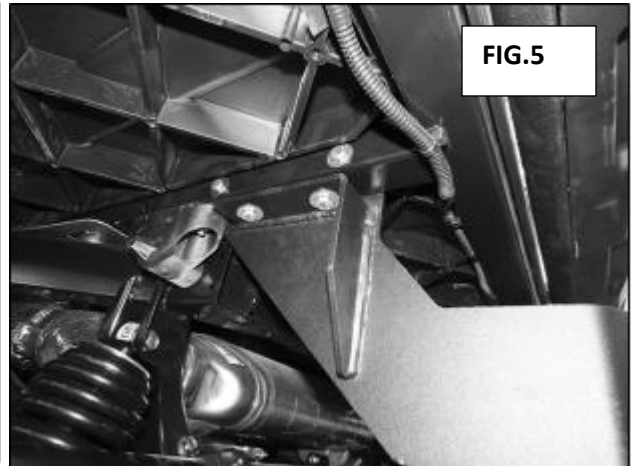
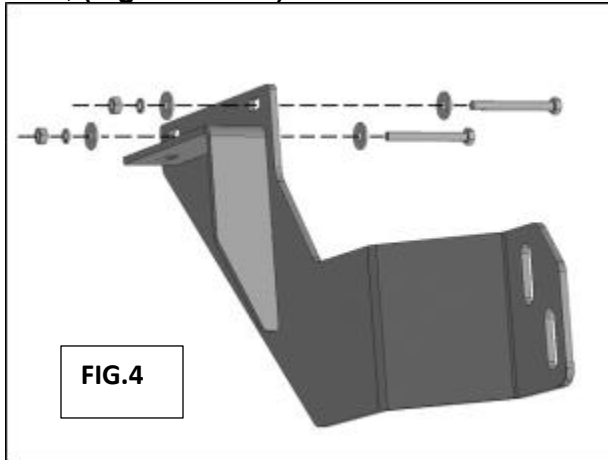

- Attach the Mounting Bracket to the previously installed threaded inserts (**see Step 2**) in the bottom of the square tube frame with the included (2) 8mm x 30mm Hex Bolts, (1) 8mm Lock Washers and (2) 8mm Flat Washers, (**Figures 5 & 6**). Do not fully tighten hardware at this time. Repeat **Steps 1—5** to install the passenger/right Mounting Bracket. **NOTE:** Pull clips from side of frame attaching wiring harness, (**Figure 7**). Once Bracket is installed, snap clips into top plate on Bracket, (**Figure 8**).

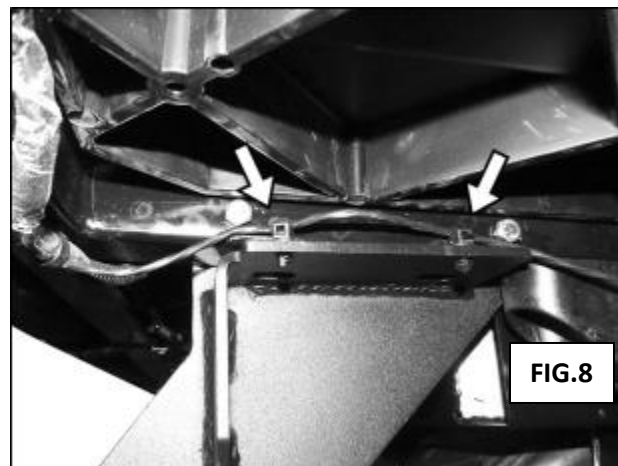
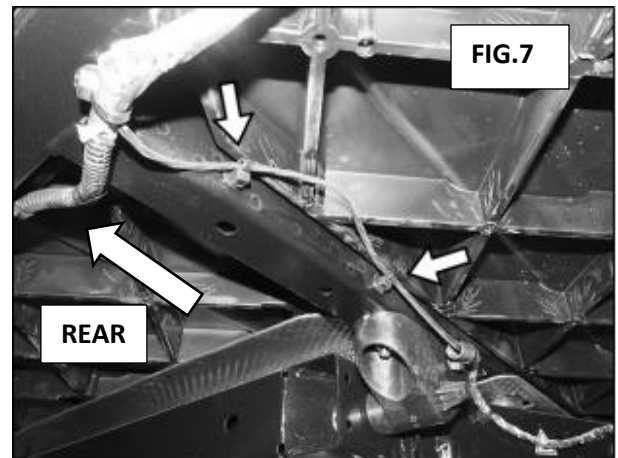
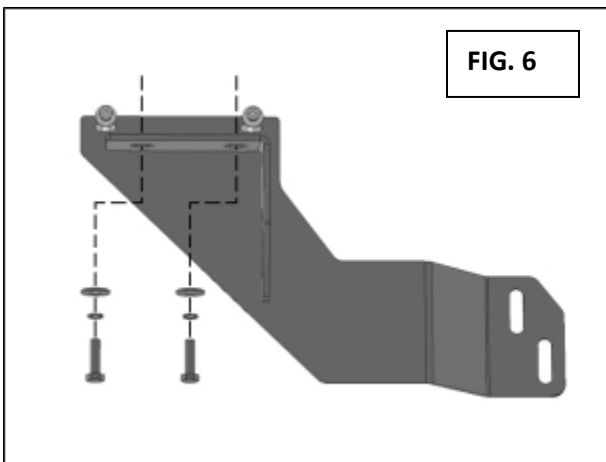

- With assistance, hold the Rear Bumper assembly up to the inside of the Mounting Brackets. Temporarily support the weight of the Bumper. **WARNING:** To avoid possible injury or damage to the vehicle, do not proceed until the Bumper is fully and safely supported. Attach the Bumper to the inside of the Mounting Brackets with the included (4) 10mm x 30mm Hex Bolts, (8) 10mm Flat Washers, (4) 10mm Lock Washers and (4) 10mm Hex Nuts, (**Figures 9 & 10**). Snug but do not fully tighten hardware at this time.
- Level and adjust the Bumper and fully tighten all hardware.

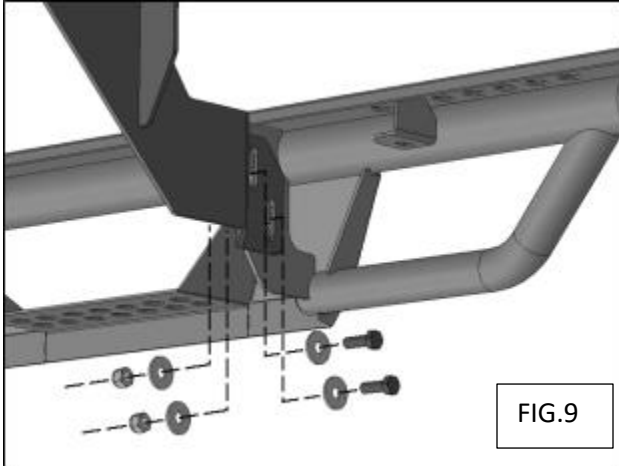

Zbrozracing.com

customerservice@zbrozracing.com

435-753-7774