

# **Kawasaki Brute Force** **650 / 650i / 750 / 750i**

## **Winch Mount**

**PART # 100535**

### **Kit Components:**

<u>Qty</u>	<u>Part Description</u>
1.....	Winch Mount
2.....	1/4"-20 x 1" x 1-1/2" " U-Bolt (A)
2.....	5/16"-18 x 1-1/4 x 1-3/4" " U-Bolt (B)
2.....	5/16"-18 x 1-1/2 " x 2-3/16" U-Bolt (C)
4.....	1/4" Nylock Nuts
8.....	5/16" Nylock Nuts
8.....	5/16" SAE Flat Washers

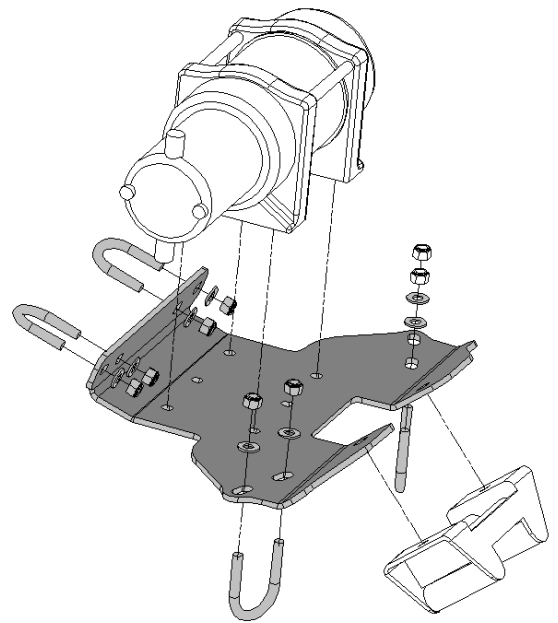

## **INSTALLATION INSTRUCTIONS:**

**NOTE:** Skip Step 1 if you are installing on a Brute Force 750, 750i or 650i

1. Begin by removing the LH plastic Side Radiator Shroud located in the front LH wheel well by removing the (4) screws as shown in "Figure 1". Not required but you can also remove (2) of the screws from the RH side to remove the bottom plastic radiator shroud that you will see after you have removed the LH shroud.

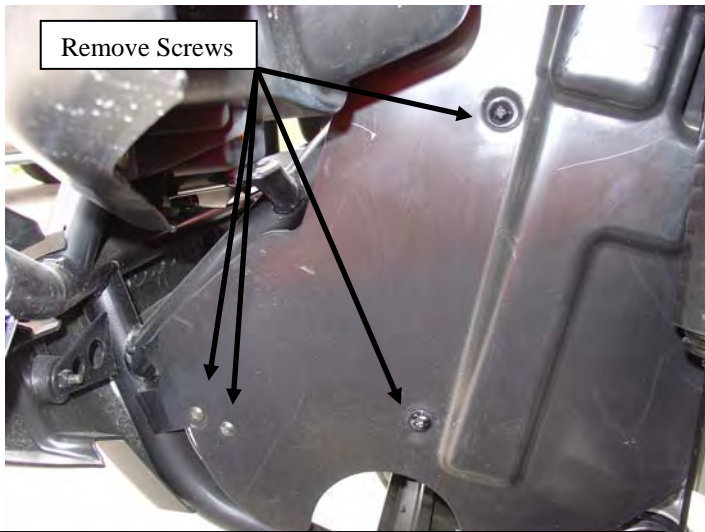

Figure 1 Remove LH Plastic Radiator Shroud (Brute Force 650 ONLY)

2. Place the Mount into position as shown in "Figure 2". The mount can be put into position from either the side or from the front by rotating the mount sideways.

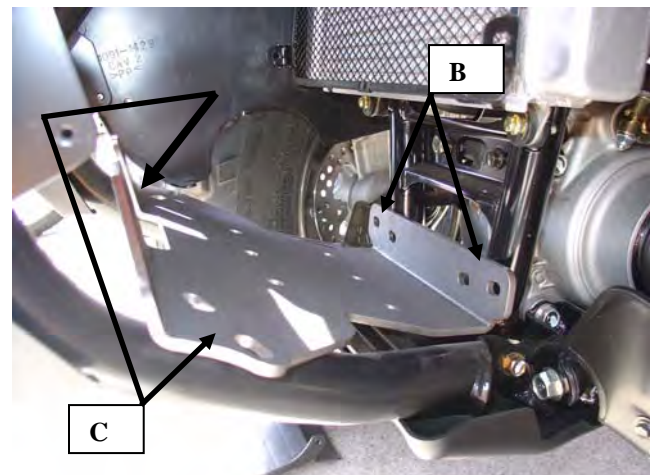

Figure 2 Place mount into position (Brute force 650 Shown)

3. If installing on a Brute Force 750, 750i, or 650i you will need to remove the bottom front plastic skid plate by removing the (2) front bolts. See "Figure 3"

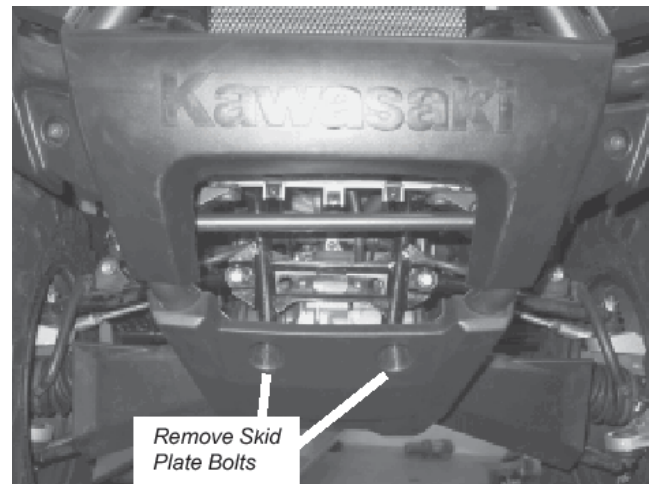

Figure 3  
Brute Force 750, 750i, and 650i ONLY  
(Brute Force 750 shown)

4. Put your winch into position and fasten it to the mount using the hardware that came with your winch. *Torque to “9 ft-lbs (12 N-m)”*
5. Fasten the roller or hawse fairlead to the mounting plate using the hardware that came with your fairlead or winch kit.
6. Place the Four supplied U-bolts (B and C) around the ATV frame and through the mounting plate in the locations shown in “Figure 2”. Fasten the supplied washers and nuts to the U-bolts to the recommended Torque of “17 lb. ft. (12.5 N-m)”
7. Using the instructions with your Winch, Wire accordingly
8. After wiring is complete replace items from Step 1 and 3 if removed.

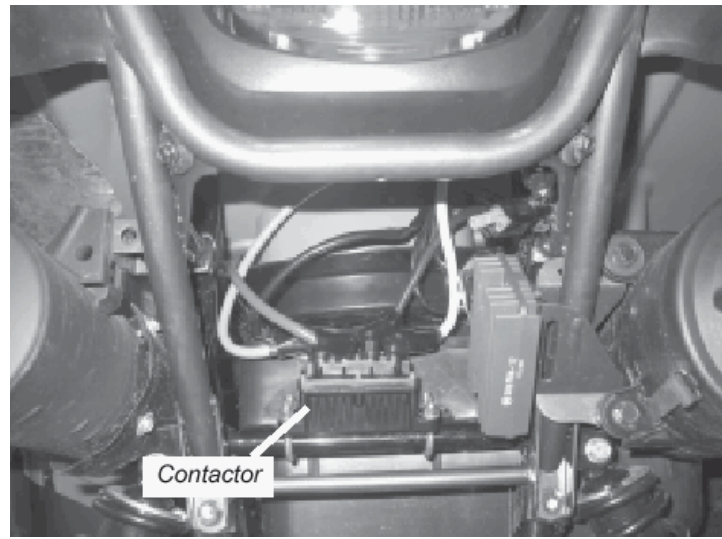

Figure 4 Contactor Location – Rear Cross Tube  
(Brute Force 750, 750i, and 650i ONLY)

**ADDITIONAL INFORMATION**

**NOTE:** *This information is for the Brute Force 750, 750i, and 650i only. This will not pertain to the Brute Force 650. On the Brute Force 650 you will need to find a good location for the contactor. As for wire routing, avoid all moving and potentially hot components.*

1. Included with this kit are (2) ¼” U-bolts and hardware. These U-bolts can be used to fasten the Winch Contactor Block to the not required but recommended location. (Some winch contactors may not work with these U-bolts)
2. The recommended contactor location is on the back of the vehicle on the rear cross tube as shown in “Figure 4”. Secure contactor with the supplied ¼” U-bolts and nuts. Do not over tighten U-bolts, this may damage the contactor.
3. You can also route the battery cables to the contactor as shown in “Figure 5”

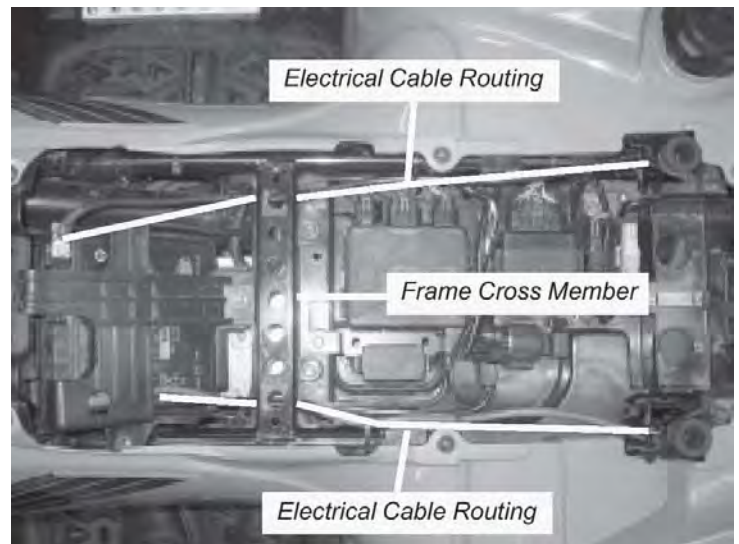

Figure 5 Battery to Contactor Cable Routing  
(Brute Force 750, 750i, and 650i ONLY)

