

LTK-C1D-1 HD ADJ

LONG TRAVEL KIT FOR THE CAN-AM DEFENDER 1000 2020+



HIGHLIFTER

SEIZMIK™



✉ sales@highlifter.com
☎ 800-699-0947 | 8:00am - 5:00pm CST
📍 7455 Atkinson Drive, Shreveport, LA 71129



www.highlifter.com

Parts Available For These Popular Brands and Others

POLARIS

can-am



HONDA

Kawasaki

YAMAHA

PRODUCT DISCLAIMER

The installation of products sold or manufactured by High Lifter Products, Inc. including, but not limited to suspension components such as lift kits, gear reduction lifts, frame stiffener kits, snorkels, and tires that exceed the original specifications for the vehicle, may change the vehicle's center of gravity and handling characteristics both on- and off-road. You are aware that the installation of tires that are larger than original vehicle specifications may reduce the effectiveness of the braking system. Use of these products may place added stress to the original factory vehicle components which could cause them to weaken or possibly fail.

Products sold or manufactured by High Lifter Products, Inc. are intended for off-road use only. Operation of a vehicle modified with these products on a road could result in serious bodily injury or death, and such operation may violate the laws of your state or municipality. You agree to operate your vehicle exclusively in the manner intended by the vehicle manufacturer. You agree that failure to safely and reasonably operate your vehicle could result in serious bodily injury or death, and that, as a result of installation of this product(s) to your vehicle, extreme care must be taken to prevent vehicle rollover or loss of control, which may be more likely to occur as a result of said modifications. You will avoid unsafe maneuvers, including sudden sharp turns or other abrupt maneuvers, which could make a vehicular accident more likely. You understand that High Lifter Products, Inc. is not responsible or liable for any damages or any injuries to yourself or your passengers that could occur upon possible accidents due to driver error, incorrect installations, bad judgment, incompatibility with other aftermarket accessories or natural disasters to the fullest extent allowable by law.

You will have all vehicle occupants fasten seatbelts, if equipped, and wear proper safety equipment, such as DOT approved helmet and eye protection prior to operating the vehicle. You understand and acknowledge that failure to wear proper safety equipment may increase the risk of serious bodily injury or death to yourself and any passengers.

Proper installation of products sold or manufactured by High Lifter Products, Inc. requires knowledge of the factory recommended procedures for removal and installation of original equipment components. Installation of these products without proper knowledge and experience may affect the performance of these components and the safety of the vehicle and cause serious bodily injury or death. It is strongly recommended that a certified mechanic familiar with the installation of similar components perform the product(s) installation.

Prior to installing any products sold or manufactured by High Lifter Products, Inc., you will perform or cause to be performed an inspection of their vehicle to confirm its condition is suitable for the installation of these products. A proper inspection of the vehicle includes confirmation that the vehicle has not been in a collision and is free of corrosion. If the vehicle is suspected to have been in a collision or misused, or is otherwise unsuitable for modification, you will not install the product(s). You will continue to inspect the vehicle prior to each use to confirm its condition is suitable for its intended use, and you acknowledge that the failure to do so may result in serious bodily injury or death, as well as damage to the vehicle itself.

You will install any warning labels provided with the product so it may be prominently seen by yourself and all passengers. You will notify all passengers of the modifications performed to your vehicle prior to operation.

Insurance companies may handle coverage of a modified vehicle differently. Please check with your insurance carrier prior to modifying the vehicle to ensure your coverage remains sufficient.

Installation of this product(s) may void your vehicle warranty. If this is a concern, please check with the manufacturer or dealer before purchase or installation of this product(s).

HIGHLIFTER

PARTS DIAGRAM

HARDWARE & BRACKETS

LTK-C1-B1B | 79-16416



MCS10X110-10.9
54-60968
M10X110mm Bolt
(2ea)



Lower Spring Retainer
79-16423
(2ea)



73-16573-L
Front Left Lift
Bracket (1ea)



73-16573-R
Front Right Lift
Bracket (1ea)



Exhaust Clamp
71-11188
(1ea)



45 Exhaust Elbow
71-11189
(1ea)



MCS10X70-10.9
54-60979
M10X70mm Bolt
(2ea)



73-16581
Lift Bracket Spacer
(2ea)



133B
79-14813
Brake Line
Clamp (2pk)



80P
73-12736
Rear Spring
Spacer (2ea)



MFW10
54-61026
10mm Flat
Washer (24ea)



MLN10-1.5
54-61038
10mm Lock
Nut (12ea)



MCS10X55-10.9
54-60976
M10X55mm Bolt
(10ea)



GF-1428-ST
54-60793
Straight Grease
Fitting (8ea)



47S
73-11678
Steering Stop
(4ea)



Spring Retainer
79-16387
(4ea)



MFW12
54-61027
12mm Flat
Washer (4ea)



MLN12-1.75
54-61040
12mm Lock Nut
(2ea)



MCS12X30-10.9
54-60996
M12X30mm Bolt
(2ea)



T11RB
54-61334
11" Zip Ties
(4ea)

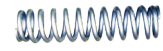

Spring
79-16371
(4ea)

TIE ROD & STEERING SET UP

(XLK-C5-B4) 79-14998

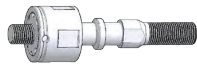

HL-TRE-002
78-10225
Inner Tie Rod
End (2ea)



79-14876
Tie Rod
(2ea)



18D
73-10858
5/8 - 18 Heim
(2ea)



MCS10X75-10.9
54-60980
M10x75mm
Bolt (2ea)



LJN58F
54-60930
Left Handed
Jam Nut (2ea)



MFW10
54-61026
10mm Flat
Washer (2ea)



79-14871
Misalignment
Cone
(4ea)



MLN10-1.5
54-61038
10mm Lock
Nut (2ea)



JN58F
54-60882
Right Handed
Jam Nut (2ea)

HIGHLIFTER

PARTS DIAGRAM

BRAKE LINE EXTENSIONS

14" BRAKE LINE EXTENSION
79-15280
(4ea)



BRAKE LINE HARDWARE



5mm Washer
54-61030
(4ea)



Loom Clamp
73-15076
(2ea)



5mm Bolt
54-61003
(2ea)



5mm Nut
54-61041
(2ea)

AXLES



DHT-XL-C1D-FL
64-10836
FRONT Left Axle (1ea)

DHT-XL-C1D-FR
64-10837
FRONT Right Axle (1ea)



DHT-XL-C1D-R
64-10838
REAR Axle (2ea)

HIGHLIFTER

PARTS DIAGRAM

FRONT LOWER & UPPER ARMS

LTK-C1-B2B | 79-16417

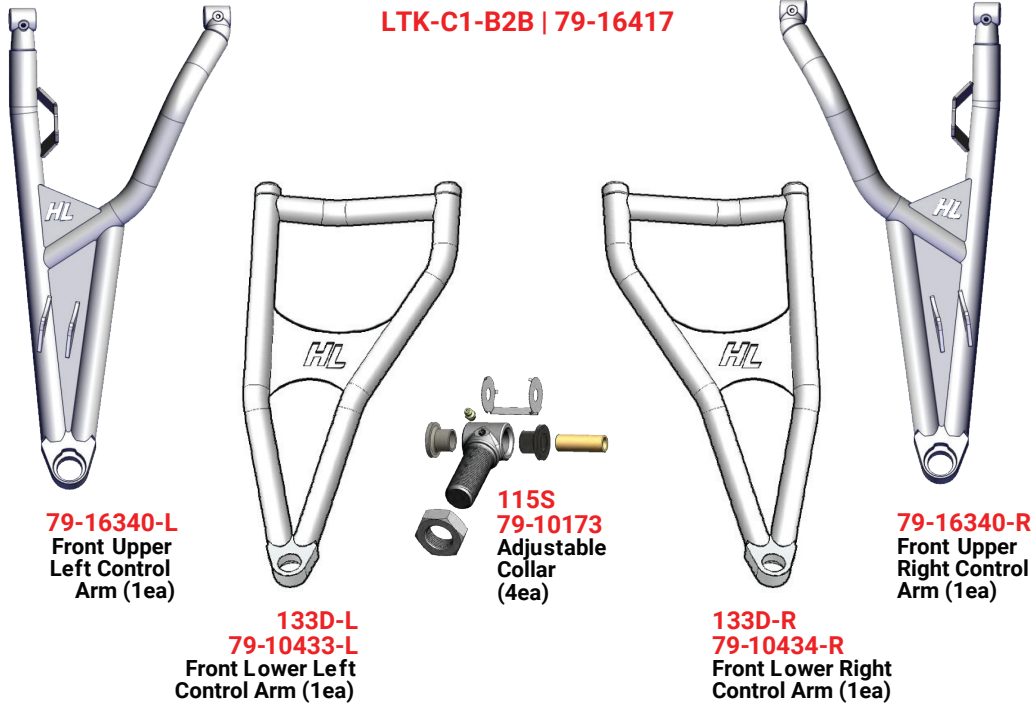

REAR LOWER & UPPER ARMS

LTK-C1-B3B | 79-16418

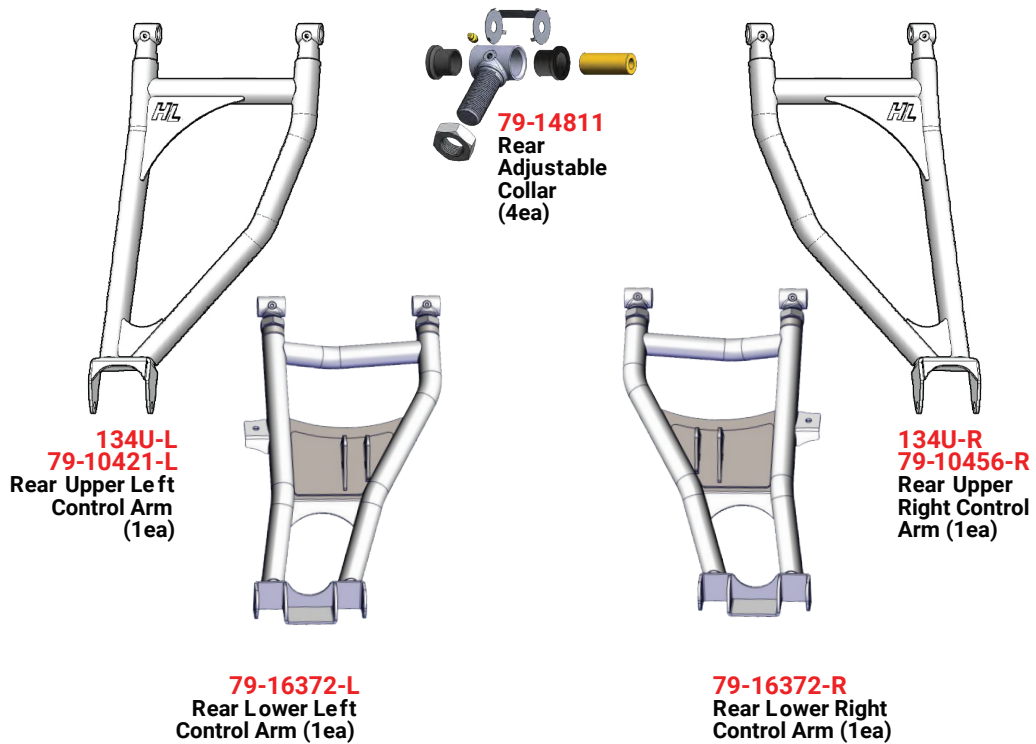

Front INSTALL

FRONT WHEELS

Removal

1



FRONT PASSENGER SIDE

KEEP ALL FACTORY HARDWARE.

Place jack under the **FRONT** center of the UTV and lift until the weight is off the suspension. Ensure that the vehicle is properly secured, so that it is stable on the jack.

Make sure that the jack is tall enough to raise the UTV high enough to reinstall the tires after the lift is installed. **ONCE LIFTED, USE JACK STANDS TO PROPERLY SECURE THE UNIT.**

Remove the **FRONT** wheels.

BRAKE CALIPER & BRAKE LINES

Removal

2

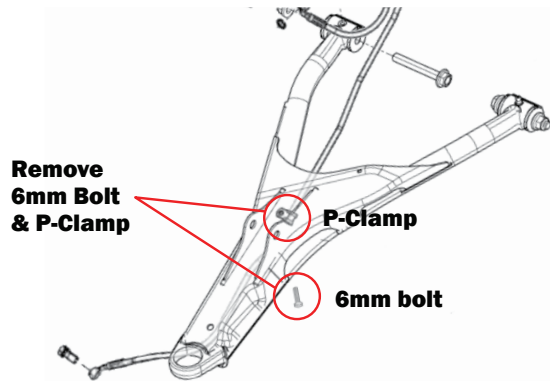

Remove
6mm Bolt
& P-Clamp

P-Clamp

6mm bolt

Disconnect brake lines by removing clamps and hardware along the upper arm. **DO NOT DRAIN FLUID YET.**

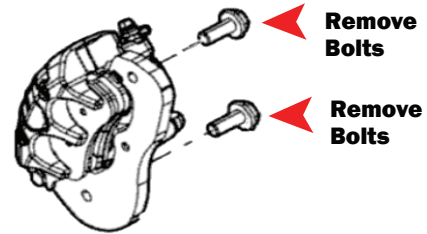

Remove
Bolts

Remove
Bolts

Remove the brake caliper mounting bolts (15mm) Set caliper aside.

HUB ASSEMBLY

Removal

3

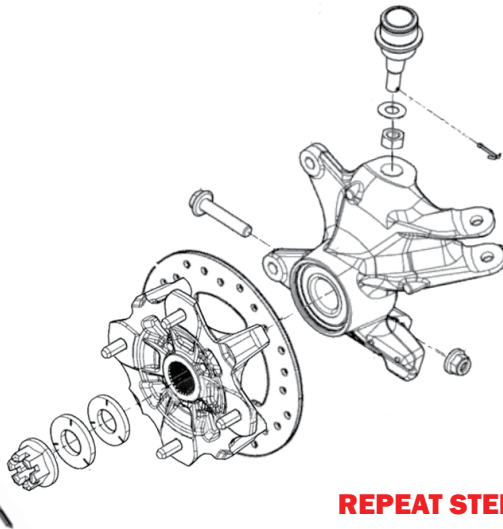

Remove the cotter pin, axle nut, and washers from the hub assembly, then remove the hub. (30mm)

REPEAT STEPS ON OPPOSITE SIDE

Front INSTALL

BALL JOINTS & TIE RODS

Removal

4

TIE ROD END

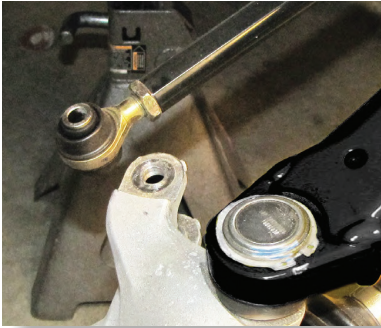

Disconnect the tie rod from the knuckle. (15mm)

UPPER BALL

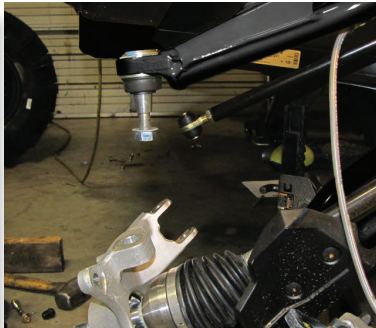

Disconnect the Upper ball joint by removing the cotter pin and bolt. (19mm)

LOWER BALL JOINT



Disconnect the Lower ball joint by removing the bolt at the knuckle. (15mm)

KEEP ALL FACTORY HARDWARE.

REMOVING STOCK COMPONENTS

Control Arms

5

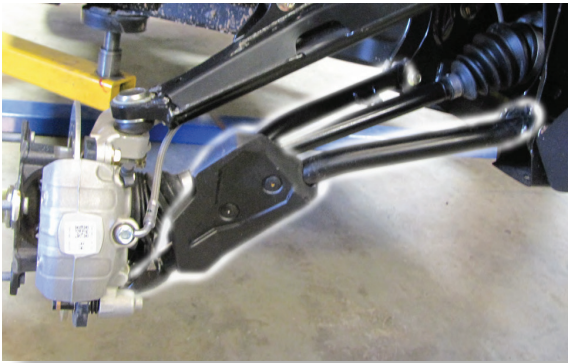

Remove the Lower Arm FIRST by removing the bolts at the knuckle (15mm) and the frame. **KEEP ALL FACTORY HARDWARE.**



Disconnect the Upper arm by removing the bolts at the knuckle, sway bar, shock, and the frame. **KEEP ALL FACTORY HARDWARE.**

Remove the axle.



6



Remove the shock

REPEAT STEPS ON OPPOSITE SIDE

7

Front INSTALL

FRONT SPRING SPACER & BUMP STOP

Install

7



BEFORE STARTING

- You will need a spring compressor to install the spring spacers onto the factory shocks.
- Adding Spacers will stiffen the ride of the vehicle.
- REMOVE THE FRONT SHOCK FROM UTV.

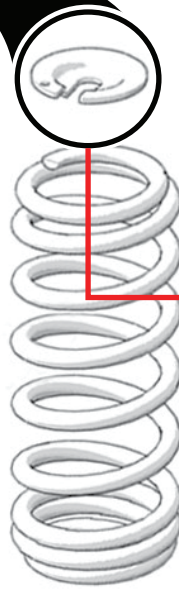

1 SPRING RETAINER

Remove the spring retainer and stock spring from the shock then install the spring retainer that came in your kit. (79-16387) Then install the lower spring retainer that came with your kit (79-16423) only if the machine has a 1.75" diameter shock.

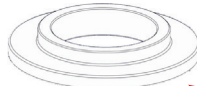

Lower Spring Retainer



8

REPEAT STEPS ON OPPOSITE SIDE

8 UPPER ARM

IF YOU ORDERED ARMS WITH PRE-INSTALLED BUSHINGS SKIP THIS STEP. THE BUSHING REMOVAL PROCESS IS THE SAME FOR ALL ARMS.

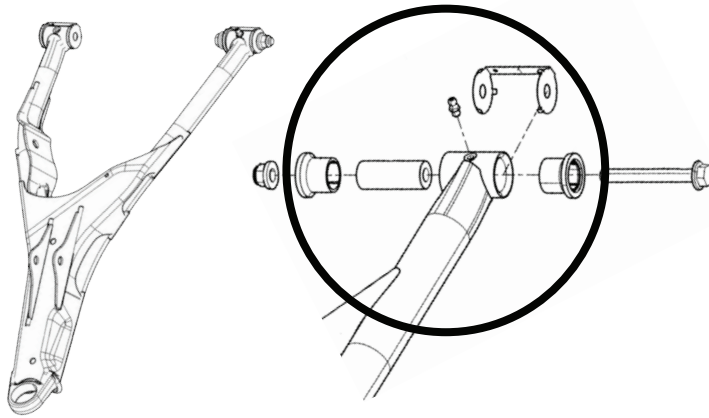

REMOVAL

Slide the sleeve out of the arm. Use a flat head screw driver to remove the bushings from the control arm; be careful not to damage them. Inspect them for wear. Replace as needed.

9

COLLAR

THE INSTALLATION PROCESS IS THE SAME FOR BOTH THE FRONT AND REAR COLLARS.

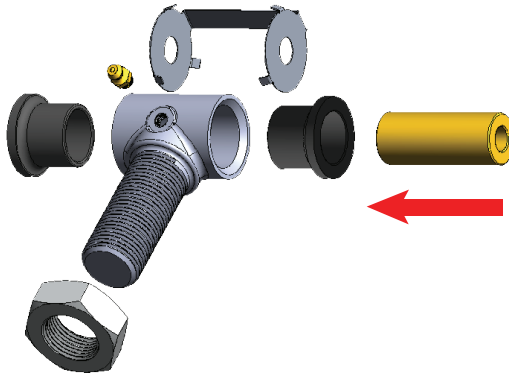

INSTALL

Once the bushings are inserted, slide the sleeve in, then clip on the wear plate.

Applying grease to the bushings and sleeves will make the installation easier.

REPEAT STEPS ON OPPOSITE SIDE

Front INSTALL

BALL JOINTS

Removal

10 IF YOU HAVE PRE-INSTALLED BALL JOINTS SKIP THIS STEP.

NOTE: FOR DEMONSTRATIVE PURPOSES WE USED THE LOWER CONTROL ARM, BUT THE PROCESS IS SIMILAR FOR BOTH. A press or a vise is suggested for removing and replacing the ball joints.



Remove Retaining Clip

Back the ball joint with a large 36mm socket or something sturdy of similar diameter, then using a press or vice, press the ball joint out of the arm.

BALL JOINTS

Install

11 Flip the control arm over, and using the same process, press the ball joint in using a vice or press. If you press in the ball joint crooked, DO NOT TRY TO FORCE IT IN. If you try to force it straight you can "egg" the opening. Press the ball joint out and reinsert it into the opening, pressing it in with a vise. Verify that the clip snaps into place after installing the ball joints into the new Control Arm. You should always double check the ball joint snap ring for proper fit. Even if you use snap ring pliers, it may not seat. You can use a flathead screwdriver and a hammer to tap the snap ring to ensure that it is seated into the groove.

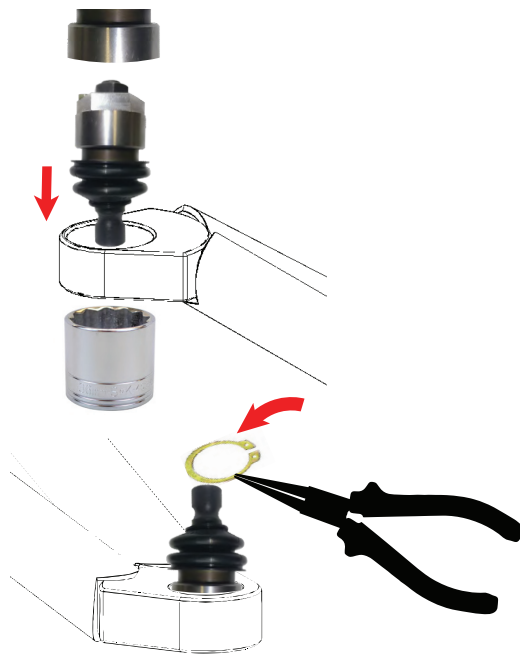

Snap the retaining clip down on to the base of the ball joint.

BALL JOINT ORIENTATION



10

REPEAT STEPS ON OPPOSITE SIDE

13 **NOTICE: DO NOT remove the steering assembly. The images featured are for DEMONSTRATIVE PURPOSES ONLY.**

BOOT REMOVAL

The rubber boots on the rack and pinion are held on by zip ties. You will need to cut the zip tie that secures the boot to the inside of the rack and pinion.

START WITH THE DRIVER'S SIDE

This side has the least amount of room. Once you install the spacer on the passenger side you will have less play on the driver's side. **DO NOT REMOVE THE FACTORY SPACER ALREADY IN PLACE.** Turn the steering wheel all the way to the **RIGHT**.

PASSENGER SIDE

Turn the steering wheel all the way to the left. Place the steering stop (47S) between the inner tie rod joint and the rack and pinion. It is a tight fit, so you may have to force it on, this is to ensure that the spacer stays in place.

RE-SECURING BOOT

You will need to turn the steering wheel closer to the center to allow play in the boot. Slide the boot back down and secure it with an 11" zip tie.

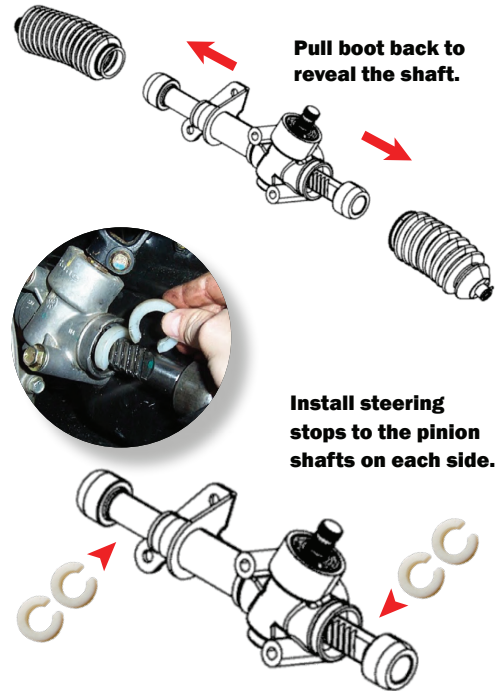

TIE ROD

14



Lightly apply blue loctite to the inner tie rod, where it connects to the rack and pinion.

**INNER TIE ROD (HL-TRE-002)
(LEFT HAND THREADED)**



**HEIM JOINT (18D)
(RIGHT HAND THREADED)**

LEFT HAND THREADED



Install the boot over the (HL-TRE-002) inner tie rod, thread on the left hand jam nut, then thread on the (79-14876) tie rod to the inner tie rod end.

RIGHT HAND THREADED



Install the heim joint (18D) and right hand jam nut to the opposite end. This will likely need to be adjusted later.

SECURE TIE ROD TO INNER TIE ROD END



You will need to turn the steering wheel closer to the center to allow play in the boot. Slide the boot back down and secure it with an 11" zip tie.

SECURE BOOT WITH 11" ZIP TIE



REPEAT STEPS ON OPPOSITE SIDE

15 FRONT LIFT BRACKET

REMOVE THE SHOCK IF YOU HAVE NOT DONE SO ALREADY.



Connect the upper portion of the lift bracket at the stock shock location using a 10x70mm bolt and 10mm washer, insert the (73-16581) Spacer between the lift bracket and run the bolt through it, then through the SS Spacer. Secure it with a 10mm washer and 10mm lock nut on the backside.

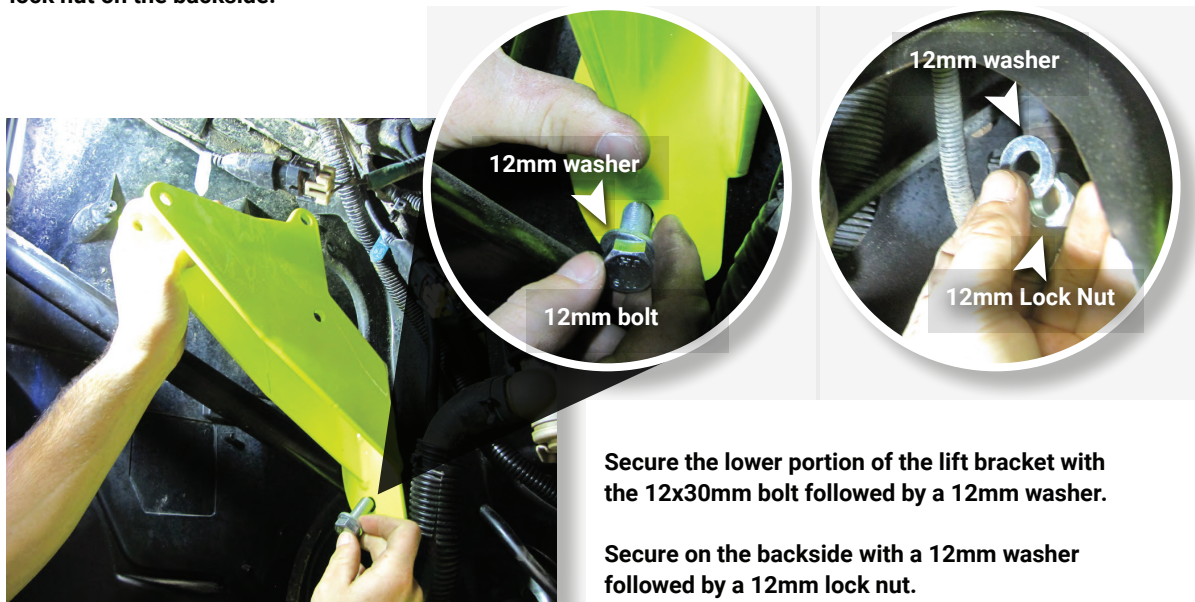

Secure the lower portion of the lift bracket with the 12x30mm bolt followed by a 12mm washer.

Secure on the backside with a 12mm washer followed by a 12mm lock nut.

16

LOWER ARM



Install the new lower control arm to the frame, using the factory hardware.

AXLE



Install the new front axles into the differential.



17

UPPER ARM



Secure the new upper control arm to the frame, using the factory hardware.

KNUCKLE



Secure the arms to the knuckle at the pinch bolt and the lock nut on the upper portion of the knuckle. Install cotter pin.

18

SHOCK



Use a 10X55 bolt followed by a 10mm washer to secure the **UPPER** shock to the lift bracket. Secure bolt with 10mm washer and 10mm lock nut.



Use a 10X55 bolt followed by a 10mm washer to secure the **LOWER** shock to the lift bracket. Secure bolt with 10mm washer and 10mm lock nut.

REPEAT STEPS ON OPPOSITE SIDE

Front INSTALL

OUTER TIE ROD END

Install

19



Install the (2) misalignment cones to the heim joint.



Run the 10X75 bolt through the tie rod.



Secure tie rod bolt with a 10mm washer and 10mm lock nut.



M10x75mm Bolt (2ea)



10mm Flat Washer (2ea)



10mm Lock Nut (2ea)



Misalignment Cone (4ea)

HUB & CALIPER

Install

20

HUB

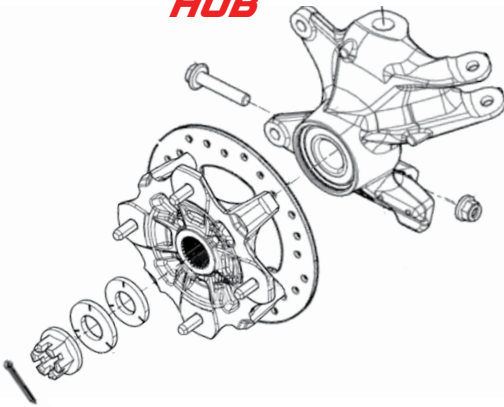

Reattach the rotor to the knuckle assembly. Install washers and secure using the axle nut and cotter pin. (30mm)

CALIPER



Connect the caliper to the hub assembly.

THE BRAKE LINE ROUTING INSTRUCTIONS FOR BOTH FRONT AND REAR ARE INCLUDED ON PAGES 23-25.



Rear INSTALL

REAR LIFT

Install

21



REAR PASSENGER SIDE

KEEP ALL FACTORY HARDWARE.

Place jack under the **REAR** center of the UTV and lift until the weight is off the suspension. Ensure that the vehicle is properly secured, so that it is stable on the jack.

Make sure that the jack is tall enough to raise the UTV high enough to reinstall the tires after the lift is installed.

Remove the **REAR** wheels.

CALIPER & HUB

Removal

22 CALIPER

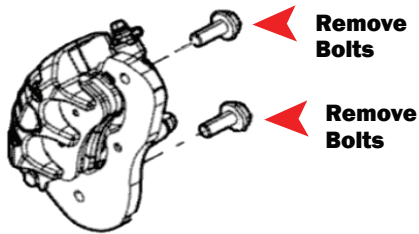

Remove the brake caliper mounting bolts from the hub assembly. (15mm) Set caliper aside.



23 HUB

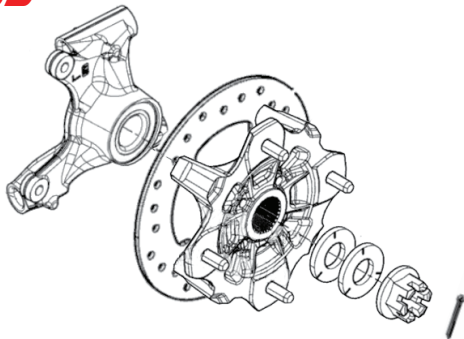

Remove the cotter pin and castle nut (30mm) on the rear axles, then remove the brake rotor assembly.



REPEAT STEPS ON OPPOSITE SIDE

24 **KNUCKLE**

Remove the bolts (15mm) and nuts that attach the rear knuckle to the upper & lower A-arms. **KEEP FACTORY HARDWARE.**



25 **LOWER ARM**

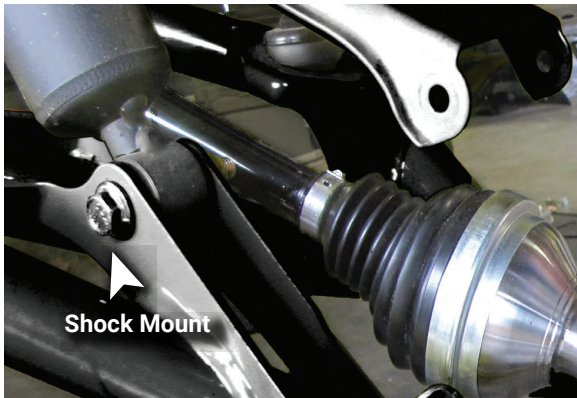

Disconnect the lower arm **FIRST** by detaching the arm at the frame, then disconnect the lower shock and sway-bar. **KEEP FACTORY HARDWARE;** it will be used to reconnect the new control arms.

26 UPPER ARM

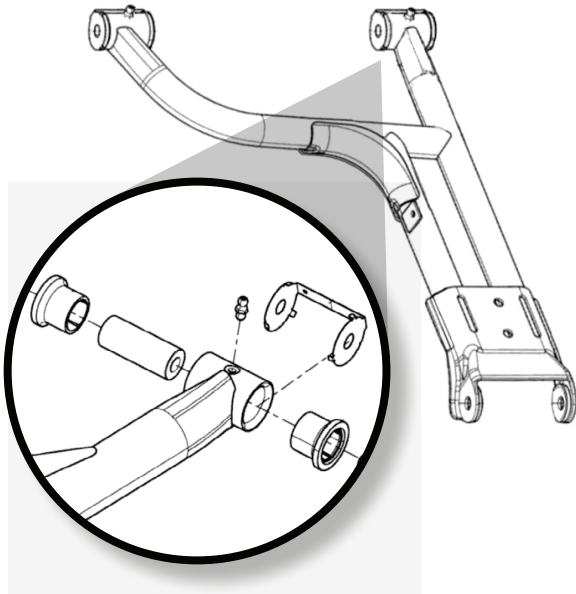

Remove the upper control arm at the frame.
Then remove stock axles.

KEEP FACTORY HARDWARE.

SET ARMS ASIDE FOR BUSHING REMOVAL.

IF YOU HAVE PRE-INSTALLED BUSHINGS YOU WILL NOT REUSE THE FACTORY BUSHINGS.

Remove the bushings, sleeve, and wear plate from the collar.

27 EXHAUST MODIFICATION

DO NOT REMOVE THE EXHAUST IF NOT NECESSARY. WHEN INSTALLING THE RIGHT REAR SHOCK, IF YOU NEED ADDITIONAL SHOCK/SPRING CLEARANCE, FOLLOW STEPS BELOW.

Use a grinder to remove the exhaust tip at the line shown below.

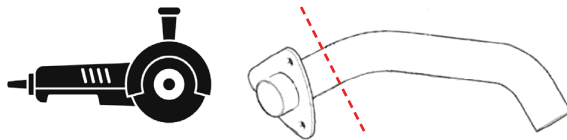

Once the exhaust is removed, install the exhaust clamp over the new exhaust at the larger end and secure it with the provided lock nuts.



Rear INSTALL

REAR LOWER CONTROL ARM

Install

28

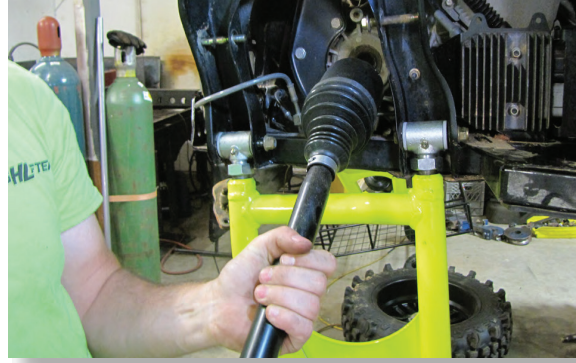
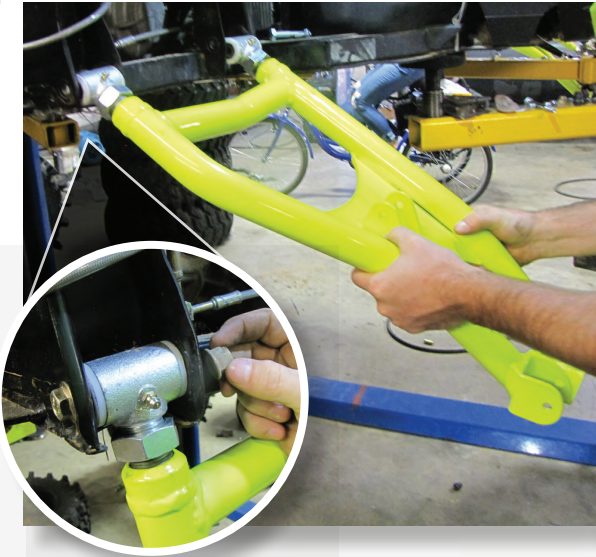

Install the rear axles.
Connect the new lower arm at the frame using the factory hardware.

REAR UPPER CONTROL ARM

Install

29



Connect the new upper arm at the frame using the factory hardware.



Connect the arms to the knuckle by using the 10mmx110mm bolt at the TOP of the knuckle. Secure with a 10mm washer and 10mm lock nut. Secure the BOTTOM portion with stock hardware

Install the rotor & hub assembly to the knuckle.
Secure with washers, axle nut, and the cotter pin

10mmx110mm bolt

Stock Bolt

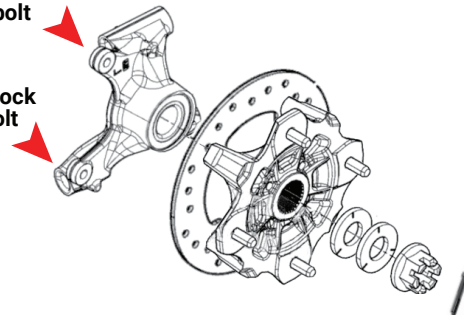

18

REPEAT STEPS ON OPPOSITE SIDE

30

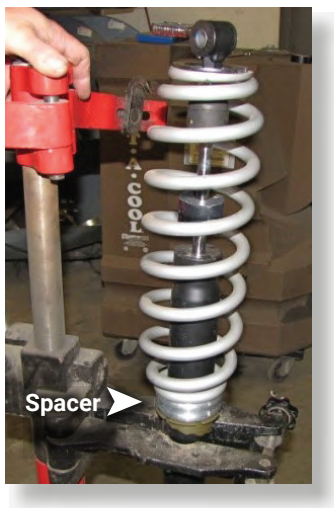

BEFORE STARTING

- You will need a spring compressor to install the spring spacers onto the factory shocks.
- Adding Spacers will stiffen the ride of the vehicle.
- REMOVE THE REAR SHOCK FROM UTV.

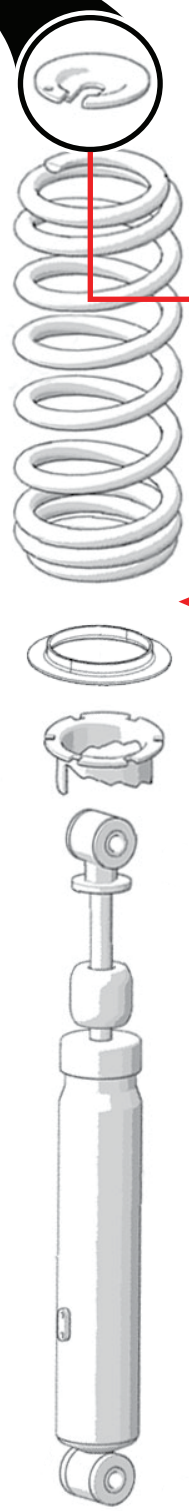

1 SPRING RETAINER

Remove the spring retainer and stock spring from the shock. You will replace the stock retainer with the spring retainer included in your kit. (79-16387)

2 SPRING SPACER (80P)

Place the spring spacer (80P) onto the shock between the adjustment cam and the spring above the lower spring retainer.

3 SHOCK SPRING

Place the spring back on the shock, compress it, and then reinstall the spring retainer.

REPEAT STEPS ON OPPOSITE SIDE

31 LOWER SHOCK



Install the shock to the lower arm shock tab.

Insert a 10x55mm bolt followed by a 10mm washer through the shock tab; secure it with a 10mm washer and 10mm lock nut.

UPPER SHOCK



Install the shock at the rear lift bracket.

Insert a 10x55mm bolt followed by a 10mm washer through the shock tab; secure it with a 10mm washer and 10mm lock nut.

BRAKE LINES EXTENSIONS

FRONT AND REAR BRAKE LINES

Removal

32

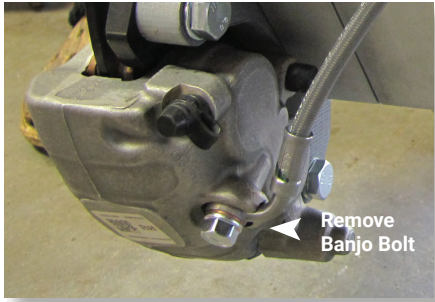

Disconnect the stock brake line from the caliper, if you have not done so already. Have a container ready to collect fluid. Now attach the brake line extenders provided in your kit and install on to the brake caliper. Use two washers on each side like in the image below when installing.

REPEAT STEP ON OPPOSITE SIDE

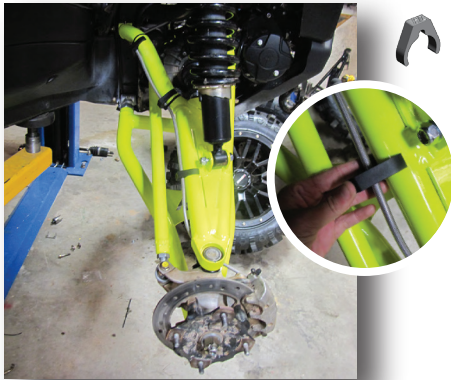

Secure the brake lines to the new control arms with the provided clamps like in the images below.

Then secure the brake line to the upper control arm with the loom clamp provided in your kit using the 5mm bolt with washers on both ends and then the nut.

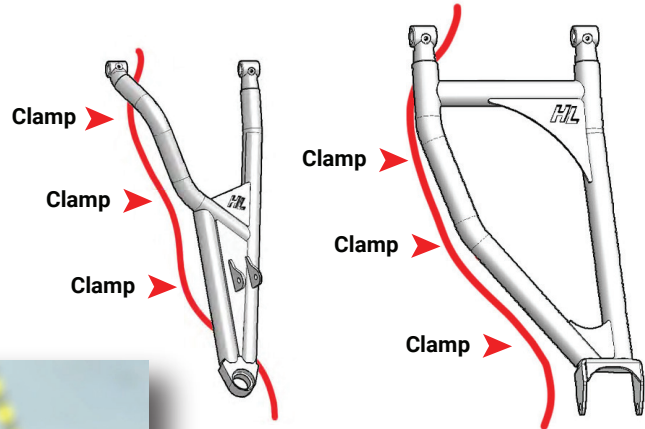

Thank You For Choosing
HIGHLIFTER

FRONT WHEEL ALIGNMENT

IF YOU HAVE ADJUSTABLE CONTROL ARMS, YOU MUST ADJUST THE CAMBER FIRST BEFORE PROCEEDING. DO NOT INSTALL WHEELS ONTO UTV UNTIL PROPER ALIGNMENT HAS BEEN ACHIEVED.

- STRAIGHTEN STEERING WHEEL
- WHILE KEEPING THE STEERING WHEEL STRAIGHT AND CENTERED ADJUST EACH TIE ROD INDIVIDUALLY TO ENSURE WHEELS ARE STRAIGHT. MEASURE FROM THE FRONT EDGE OF THE RIGHT RIM TO THE LEFT RIM WITH A TAPE MEASURE. REPEAT FOR THE REAR OF THE RIMS. ADJUST THE TOE BY ADJUSTING THE TIE ROD SO THAT YOU ACHIEVE TOE-IN OR TOE-OUT DEPENDING ON THE RIDER'S PREFERENCE.
- TAKE A TAPE MEASURE AND MEASURE FROM INSIDE TO INSIDE ON THE FRONT AND BACK ENDS OF THE ROTORS.



INCORRECT TOE

IF THE TOE ALIGNMENT IS INCORRECT, MEASURE THE DISTANCE BETWEEN VEHICLE CENTER AND EACH WHEEL. THIS WILL INDICATE WHICH TIE ROD NEEDS ADJUSTMENT.

ADJUSTING TOE

ADJUST TIE RODS UNTIL BOTH MEASUREMENTS ARE THE SAME, THEN ADJUST TOE TOLERANCE.

THE RECOMMENDED VEHICLE TOE TOLERANCE IS 1/8" TO 1/4" (3.175-6.35MM) TOE OUT. THIS MEANS THE FRONT MEASUREMENT IS WIDER THAN THE REAR MEASUREMENT.

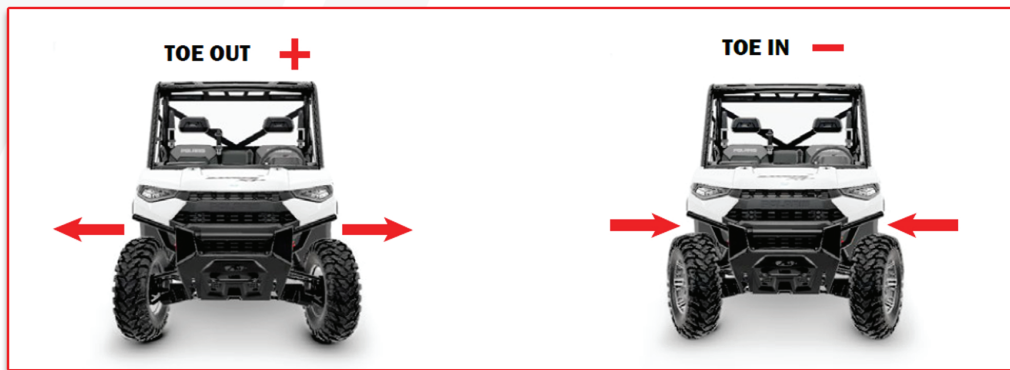

IF THE **FRONT OF THE WHEELS** ARE POINTING **OUT**, ADJUST THE TIE RODS **OUT** OR **INCREASE THE LENGTH OF THE TIE ROD**. MEASUREMENT AT THE **FRONT OF THE TIRES** WILL BE **GREATER** THAN THE REAR, IF THE **TOE IS OUT**.

TOE-OUT ALLOWS FOR QUICKER AND MORE EFFORTLESS TURNING AND ALLOWS FOR BETTER GRIP HOWEVER, IT DECREASES THE LIFE SPAN OF THE TIRE. **TOE-OUT** IS BETTER SUITED FOR UTILITY ATV'S AND SIDE BY SIDES.

IF THE **FRONT OF THE WHEELS** ARE POINTING **IN**, ADJUST THE TIE RODS **IN** OR **REDUCE THE LENGTH OF THE TIE ROD**. MEASUREMENT AT THE **FRONT OF THE TIRES** WILL BE **LESS** THAN THE REAR, IF THE **TOE IS IN**.

TOE-IN ALLOWS FOR BETTER STRAIGHT-LINE STABILITY BUT AT THE COST OF A MORE SLUGGISH TURNING RESPONSE. **TOE IN** IS BETTER SUITED FOR SPORT ATV'S AND SIDE BY SIDES.



IMPORTANT NOTE: WHEN TIGHTENING THE TIE ROD JAM NUTS, THE TIE ROD ENDS MUST BE HELD PARALLEL TO PREVENT ROD END DAMAGE AND PREMATURE WEAR. DAMAGE MAY NOT BE IMMEDIATELY APPARENT IF DONE INCORRECTLY.

AFTER ALIGNMENT IS COMPLETE, TIGHTEN & TORQUE TIE ROD END JAM NUTS TO SPECIFICATIONS. [12-14 FT LBS]

ADJUSTING WHEEL CAMBER

BEFORE STARTING

- TIRES MUST BE OFF THE GROUND
- TIRES MUST HAVE EQUAL AIR PRESSURE
- SUSPENSION COMPONENTS MUST BE COMPLETELY ASSEMBLED

THE NEW HIGH LIFTER LOWER CONTROL ARMS WILL COME PRE-ADJUSTED TO FACTORY LENGTH, WHICH IS .937

IF YOU NEED TO RE-ADJUST THE COLLARS, PLACE THE FACTORY ARM AND NEW CONTROL ARM ON A FLAT SURFACE. MEASURE FROM EYELET TO CENTER MOUNT ON THE FACTORY ARM, AND THEN ADJUST THE NEW ARMS TO THOSE LENGTHS.

NOTE: WHEN RE-ADJUSTING, LEAVE THE JAM NUTS LOOSE. DO NOT FASTEN TIGHT UNTIL INSTALLED ON UTV, AFTER ALL FINAL ADJUSTMENTS HAVE BEEN MADE.

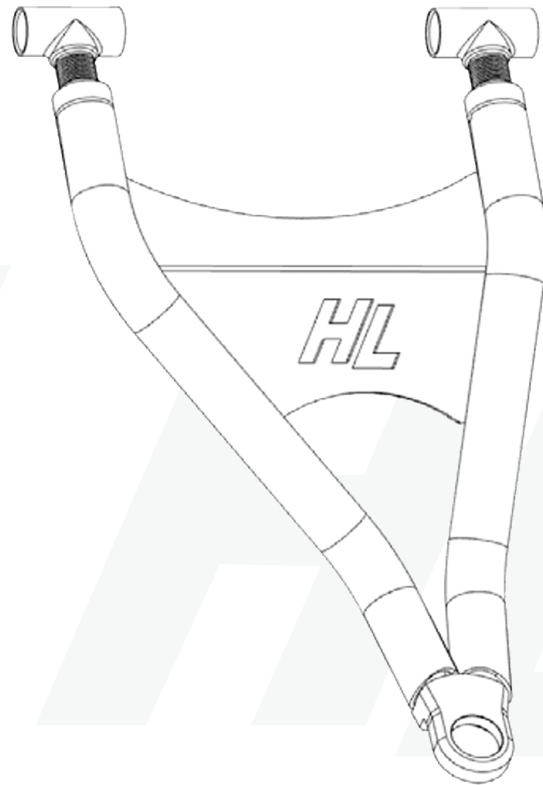

MAKE ALL ADJUSTMENTS IN SMALL INCREMENTS.

DO THIS BY **DISCONNECTING CONTROL ARMS AT THE FRAME AND ADJUSTING COLLARS.** ONCE SMALL ADJUSTMENTS HAVE BEEN MADE. TAKE THE UTV OFF THE JACK AND ROLL IT BACK AND FORTH SEVERAL TIMES TO CHECK THE CAMBER. REPEAT STEPS AS NEEDED. AFTER ALIGNMENT IS COMPLETE, TIGHTEN JAM NUTS TO 80 FT-LBS AND SECURE IT WITH BLUE LOCTITE.



POSITIVE CAMBER

IF YOU HAVE A POSITIVE CAMBER YOU WILL NEED TO ADJUST THE COLLAR OUTWARD OR LENGTHEN THE CONTROL ARM. THE MAXIMUM AMOUNT OUTWARD IS "1.250" WHICH COULD GIVE UP TO 3° OF POSITIVE CAMBER.



CORRECT CAMBER

FOR THIS APPLICATION, WE RECOMMEND A CAMBER SETTING OF 0°. COLLARS ARE PRESET TO .937



NEGATIVE CAMBER

IF YOU HAVE A NEGATIVE CAMBER YOU WILL NEED TO ADJUST THE COLLAR INWARD OR SHORTEN THE CONTROL ARM. THE MAXIMUM AMOUNT INWARD IS ZERO THREADS EXPOSED AND COULD GIVE OVER 3° OF NEGATIVE CAMBER



HIGHLIFTER



HIGH LIFTER LIMITED LIFETIME WARRANTY

High Lifter offers a Limited Lifetime Warranty to the original purchaser that our product shall be free from defects in material and workmanship for the life of the product if utilized in accordance with the manufacturer's instructions for installation and operation of said products.

LIMITED LIFETIME WARRANTY EXTENDS TO THE FOLLOWING PRODUCT LINES:

- **Lift Kits (Signature, Standard and Big Lifts)**
- **Control Arms**
- **Trailing Arms**
- **Radiator Relocation Kits**
- **Portal Gear Lifts**
- **Wheel Spacers**
- **Tow Hooks**
- **Control Arm Link Kits**

Damages to vehicle or any other object during the installation, use, or removal of High Lifter products are not covered under this warranty. Normal wear items included with any of the products covered under this Limited Lifetime Warranty are excluded from coverage. These items include, but are not limited to heim joints, tie rods, bearings, bushings, seals, gaskets, zinc plating, painted and powder coated finishes. Other exclusions of coverage under this warranty include, but are not limited to: damage or product failure due to improper installation, lack of maintenance, product modification, abuse, collision or use on vehicles for which product was not designed, repairs performed by anyone other than approved High Lifter personnel or made using non-High Lifter components. This warranty is valid for the original purchaser only and is non-transferable. High Lifter reserves the right to inspect any product before determining if the claim is valid and covered under this warranty. Claims determined to be caused by reasons other than a manufacturer defect will be rejected and an estimate for repair or cost of a replacement product if a repair is not possible, will be provided.

This warranty is exclusive and is in lieu of any implied warranty of merchantability, fitness for a particular purpose or other warranty of quality, whether express or implied, except the warranty of title.

WARRANTY PROCESSING

If you suspect your product is defective, **DO NOT** disassemble the product to determine the cause without prior approval as it may void your warranty status. This is especially true with our Portal Gear Lift. To begin the claim process, please e-mail our warranty team at warranty@highlifter.com and include the following in the e-mail:

- Your full name, address and contact phone number.
- The year, make and model of your vehicle
- The part number of the product
- Photos of the product installed, and vehicle product is installed on
- Proof of Purchase (Required for all warranty claims and you must be the original purchaser)

Once a claim is created, you will receive a return authorization number (RMA). Write this number on the outside of the box containing your defective product and include it along with your name and contact information inside the box. Product must be returned in the original box or a box of equal strength and packaging. Product sent without an RMA number visible on the outside of the box or sent COD will be refused. Ship your product to the following address:

High Lifter Products, Inc.
Attn: Returns 7455 Atkinson Dr, Shreveport, LA 71129

Once your product is received, we often have your replacement or repaired product shipped back to you within 3-business days of receiving it. Please note that High Lifter is not responsible for shipping charges on product returned for warranty or repair, including duties and fees required by those residing outside the United States.

THANK YOU FOR CHOOSING
HIGHLIFTER