



APEXX PERFORMANCE BALL JOINT LIMITED WARRANTY

High Lifter offers a 1-year Limited Warranty to the original purchaser that our product shall be free from defects in material and workmanship for the life of the product if utilized in accordance with the manufacturer's instructions for installation and operation of said products.

IF THE CAP IS USED TO PULL THE BASE INTO PLACE BEFORE IT IS PROPERLY SEATED IN THE ARM, IT WILL DAMAGE THE BALL JOINT AND VOID THE WARRANTY. USING AN IMPACT TOOL WILL ALSO VOID THE WARRANTY.

WARRANTY INFORMATION

Damages to vehicle or any other object during the installation, use, or removal of High Lifter products are not covered under this warranty. Normal wear items included under this 1-Year Limited Warranty are excluded from coverage. These items include, but are not limited to pins, boots, and zinc coated finishes. Other exclusions of coverage under this warranty include, but are not limited to: damage or product failure due to improper installation, lack of maintenance, product modification, abuse, collision or use on vehicles for which product was not designed, repairs performed by anyone other than approved High Lifter personnel or made using non-High Lifter components. This warranty is valid for the original purchaser only and is non-transferable. High Lifter reserves the right to inspect any product before determining if the claim is valid and covered under this warranty. Claims determined to be caused by reasons other than a manufacturer defect will be rejected and an estimate for repair or cost of a replacement product if a repair is not possible, will be provided.

This warranty is exclusive and is in lieu of any implied warranty of merchantability, fitness for a particular purpose or other warranty of quality, whether express or implied, except the warranty of title.

WARRANTY PROCESSING

If you suspect your product is defective, **DO NOT** disassemble the product to determine the cause without prior approval as it may void your warranty status. To begin the claim process, please e-mail our warranty team at warrantycare@highlifter.com and include the following in the e-mail:

- Your full name, address and contact phone number.
- The year, make and model of your vehicle
- The part number of the product
- Photos of the product installed, and vehicle product is installed on
- Proof of Purchase (Required for all warranty claims and you must be the original purchaser)

Once a claim is created, you will receive a return authorization number (RMA). Write this number on the outside of the box containing your defective product and include it along with your name and contact information inside the box. Product must be returned in the original box or a box of equal strength and packaging. Product sent without an RMA number visible on the outside of the box or sent COD will be refused. Ship your product to the following address:

**Attn Returns: High Lifter Products, Inc.
780 Professional Dr N Shreveport, LA 71105**

Once your product is received, we often have your replacement or repaired product shipped back to you within 3-business days of receiving it. Please note that High Lifter is not responsible for shipping charges on product returned for warranty or repair, including duties and fees required by those residing outside the United States.

**THANK YOU FOR CHOOSING
HIGH LIFTER**

BEFORE STARTING



A PRESS IS RECOMMENDED FOR BALL JOINT INSTALLATION.

The install process is similar for both arms, however, depending on stock configuration, the ball joint may go in different directions for upper and lower arms.



DO NOT USE AN IMPACT TOOL.



UPPER ARM

**TORQUE
50 FT LBS**



JAM NUT



SET SCREW

**TORQUE
150 FT LBS**



CAP



BUSHING



PIN

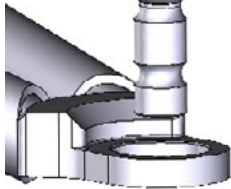

BASE HOUSING



BOOT



INSTALL ZIP TIE TO BASE

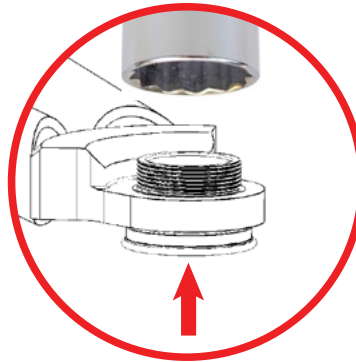

**STEP 1
INSTALL BASE**

Using a press, push the base of the HD ball joint into the arm, ensuring it seats properly.

DO NOT TIGHTEN THE CAP BEFORE PRESSING IN THE BALL JOINT. THIS WILL DAMAGE THE THREADS.



**STEP 2
ASSEMBLE COMPONENTS**

Assemble all of the components inside of the cap and base housing.

TORQUE THE CAP TO 150 FT LBS. Insert the set screw, then thread on the jam nut.

**STEP 3
BALL JOINT SETTINGS**

Using a 1/4 hex key, tighten the set screw until there is **NO VERTICAL PLAY BETWEEN THE PIN AND THE BUSHING AND NO PLAY FOR THE PIN TO SWING.** Back off the set screw about 1/16 of a turn. The pin should be able to move side to side once set, but **NOT** up and down. Once zero lash is met, **TORQUE THE JAM NUT TO 50 FT LBS.** **DO NOT OVER TIGHTEN THE SET SCREW. THIS CAN CAUSE PREMATURE WEAR.**

