



**INSTALLATION INSTRUCTIONS / OWNER'S MANUAL:  
AUDIO SHADE  
OFF-ROAD TOP FOR HONDA PIONEER 1000-5**

*www.hoppeindustries.com*  
22667 FM 15 Troup, TX 75789  
(262) 552-2770

Thank you for choosing the Hoppe *Audio Shade* off-road top. We hope you enjoy the off-road top, and we ask that you follow these instructions very closely. Doing so will save you time and ensure that your experience with the new *Audio Shade* is a positive one.

**We strongly suggest that you read the complete instructions before beginning the installation process to eliminate the possibility of performing unnecessary work.**

Having a safe and clean environment and using the proper tools is essential for a successful installation.

**It is critical that proper eye wear, ear protection, and protective clothing is worn throughout the top installation.**

When you receive your *Audio Shade* off-road top, please check to ensure that all parts and hardware are included. If there are any parts missing or if you have any questions concerning the top at this time call Hoppe at (262)-552-2770 Mon-Thur. 8am-5pm CST, or you can email us at [tech@hoppeindustries.com](mailto:tech@hoppeindustries.com).

Hoppe reserves the right to change specifications, equipment, or designs at any time without notice and without incurring obligation.

# **TABLE OF CONTENTS**

SECTION 1 – <i>Tools Required</i> .....	4
SECTION 2 – <i>About your Audio Shade Top</i> .....	4
2.1 Applicable Year Models: .....	4
2.2 Audio Equipment Details:.....	4
2.3 Warranty: .....	5
2.4 Care and Maintenance: .....	5
2.5 Warnings:.....	6
SECTION 3 – <i>Pre-Installation Inspection</i> .....	7
SECTION 4 – <i>Installation</i> .....	8

## **SECTION 1 – Tools Required**

- Socket wrench set
- Combination wrench set
- Wire cutters
- Screw drivers

In addition to the above items, you may need shop supplies such as electrical tape, wire ties, thread locking compound, or RTV silicone.


## **SECTION 2 – About your Audio Shade Top**

### **2.1 Applicable Year Models:**

This *Audio Shade* off-road top is designed to fit Honda Pioneer 1000-5 models.

- 2016-2022 Pioneer 1000-5 (all trim levels)

### **2.2 Audio Equipment Details:**

Your *Audio Shade* off-road top is powered by  using their premium quality power sports series audio equipment. This equipment is designed to function in all weather conditions with an IPX6 water resistance (powerful water jet) rating. The stereo is specifically engineered to provide excellent sound quality and volume in an open air power sports environment so you can enjoy your music on the go.

To learn more details about your stereo system, you can access product information and manuals for the stereo equipment here:

- KMC2 receiver: <https://www.kicker.com/46KMC2>
- Sub-woofer amplifier: <https://www.kicker.com/key-5001-1-channel-smart-amplifier>
- Speaker amplifier: <https://www.kicker.com/pxa3004-4-channel-compact-powersports-amplifier>
- Sub-woofers: <https://www.kicker.com/2016-comprt-subwoofers>
- Speakers: <https://www.kicker.com/42PSC654>

Your amplifier gains comes pre-adjusted from the factory and are tuned for optimum sound quality and system protection. This means you can feel free to crank the volume without much worry of harming your system. However, it is wise to use a little common sense. If you hear any distortion, back off a little. We recommend you do not adjust the gains from the factory settings without first consulting Hoppe Industries.

Please note that your subwoofer will take 20 to 30 hours of play time to fully break in and reach its maximum output. You do not need to do anything different during this break in

period. In fact, the more you listen and the louder you turn it up, the quicker you will reach the maximum potential. Use the equalizer settings in your KMC2 receiver to adjust the bass as needed throughout the break in period.

### **2.3 Warranty:**

Your *Audio Shade* comes equipped with a 1 year limited warranty covering the lights, the stereo equipment, and the fiberglass top. The date of warranty coverage will be determined by the registration date of the warranty card or online warranty registration.

<http://www.motortrike.com/TrikeAccWarranty.aspx>

If the warranty is not registered with Hoppe, the warranty period will begin when the Audio Shade was shipped from Hoppe's factory.

### **2.4 Care and Maintenance:**

Your off-road top does not require any maintenance other than an occasional cleaning. To clean your top, simply hose off or power wash from a distance. If needed, use a mild automotive soap and sponge or brush. Use common sense. Do not use a high pressure power washer up close where it could cut, scar, or force water beyond the design intent of the top, lights, or stereo equipment.

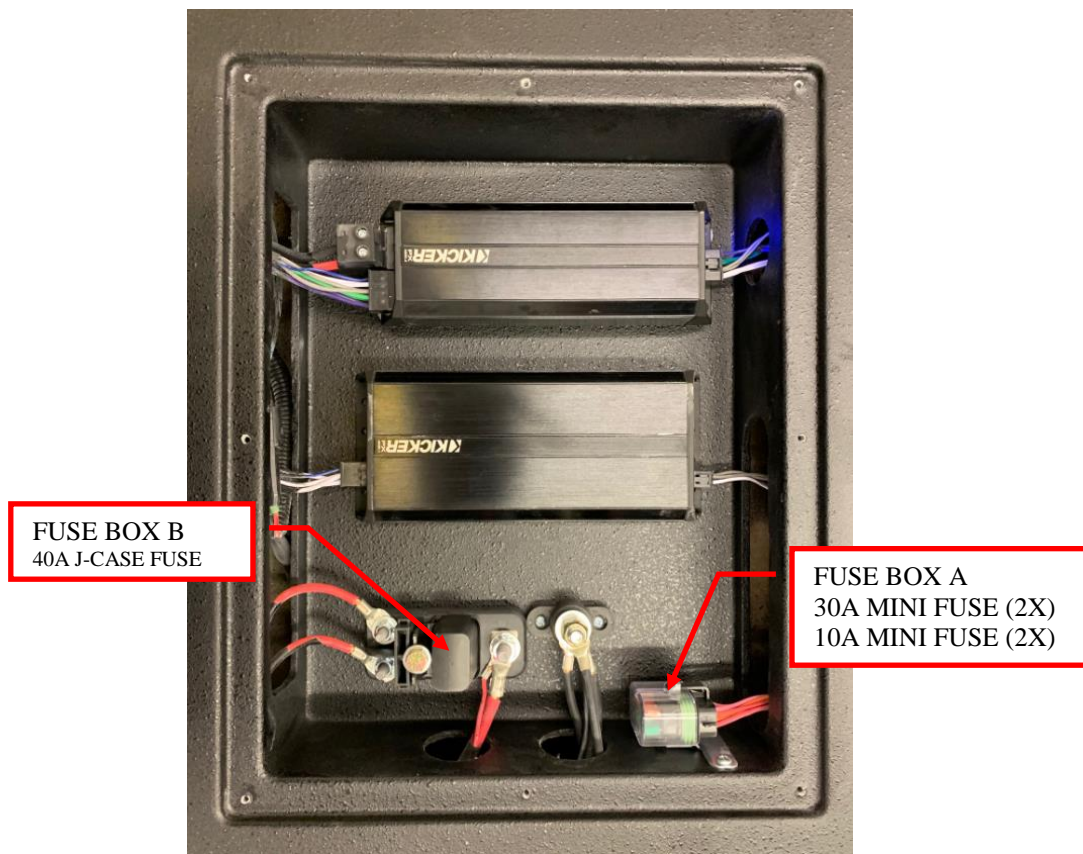
The fuse box for the amplifier, radio, light bars, and interior lights can be accessed by removing the cover plate located on the underside of your roof.

There is also a mini 40 amp ignition relay built into the chassis harness near the battery terminal end of the harness, as shown in Figure 1.



**Figure 1: Chassis harness relay.**





**Figure 2: Fuse locations.**

- Fuse 1 Box A: 30 amp mini fuse for rear light bar
- Fuse 2 Box A: 10 amp mini fuse for interior light
- Fuse 3 Box A: 30 amp mini fuse for front light bar / radio receiver power.
- Fuse 4 Box A: 10 amp mini fuse for illumination / radio receiver ignition.
- Fuse Box B: Each amplifier uses a 40 amp J-Case fuse located under the black plastic cover shown in Figure 2.

## **2.5 Warnings:**

This off-road top adds up to 150 lbs. to your vehicle and is located up high on the roll cage. This increases the vehicles center of gravity and changes the vehicle dynamics and handling characteristics. Use extra caution as you learn the driving characteristics of your vehicles performance with your new off-road top installed. High speed cornering, off camber or side hill, acceleration, and braking performance will be negatively impacted by the weight of the top.

Do not listen to your stereo at an uncomfortable volume for extended periods of time. Potential hearing loss may result.

The driving lights provided with your Audio Shade are blinding to oncoming drivers. These are made for off road use only, and should be turned off when another vehicle is approaching on the trail.

## **SECTION 3 – Pre-Installation Inspection**

Included in your off-road top are the following components:

- Pre-assembled *Audio Shade* off-road top. (All speakers and electronics come preinstalled with interior wire harness.)
- Chassis wire harness.
- Rear light bar extension harness.
- Four (4) cage clamps.
- Hardware bag.

If any of the parts are missing, damaged, or you have any questions concerning them, please call Hoppe at (262)-552-2770 Mon-Thur. 8am-5pm CST.

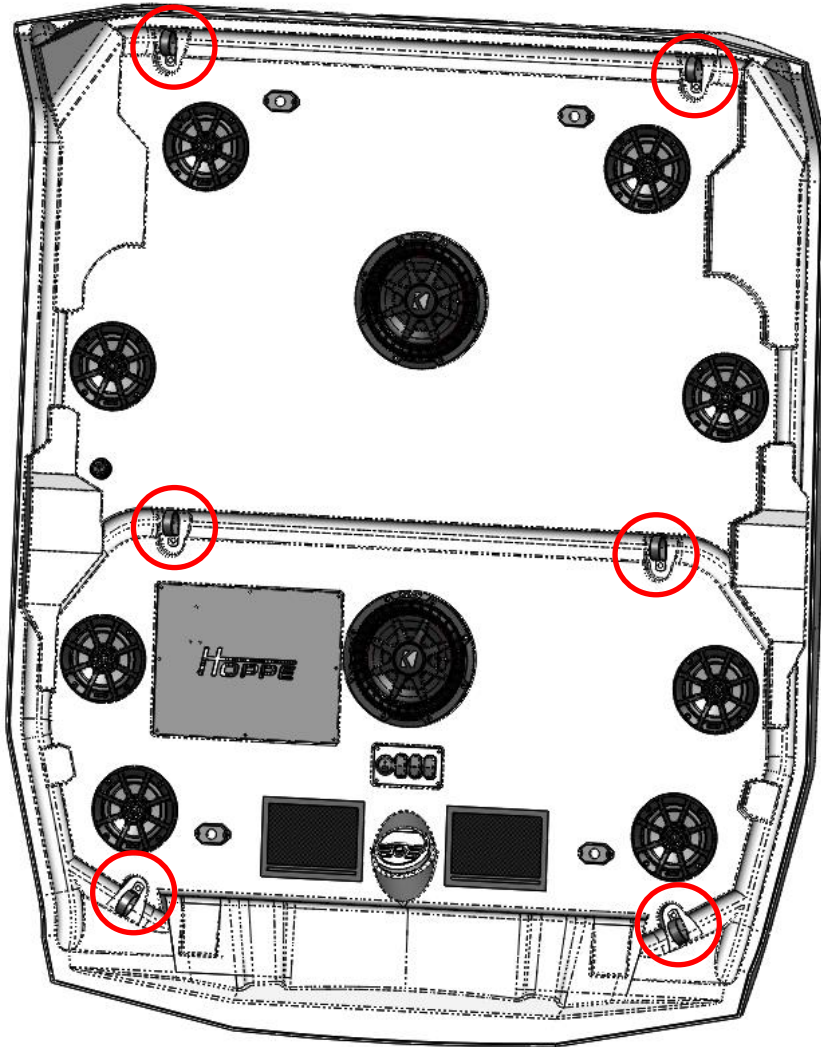
In addition to accounting for all of the parts that you should receive with the top, you should inspect the vehicle in the following ways.

- Ensure that the vehicle is equipped with the factory roll cage, and the roll cage has not been bent out of shape in a roll over.
- Make sure the vehicle does not have any aftermarket accessories that are incompatible with the top. **Note: This top is designed to be compatible with most factory windshields.**
- Make sure the battery is in good condition and holds a charge.
- Make sure the charging system is in good condition.

## **SECTION 4 – Installation**

Note: The factory roof must be removed prior to performing this installation.

1. Remove the cage clamps and 3/8"-16 bolts and washers that come pre-installed on the top. Save the hardware for installation. See Figure 3 and Figure 4.



**Figure 3: Remove the 6 clamps from the top.**



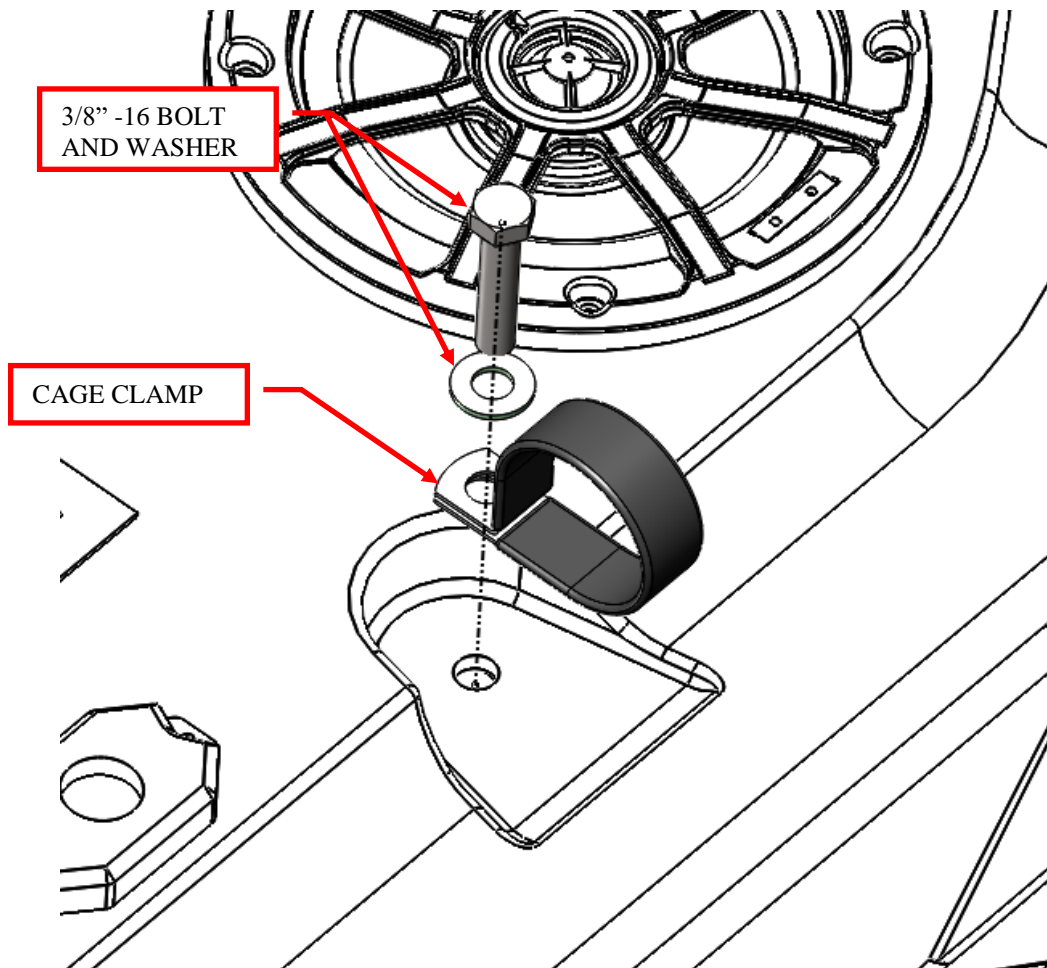
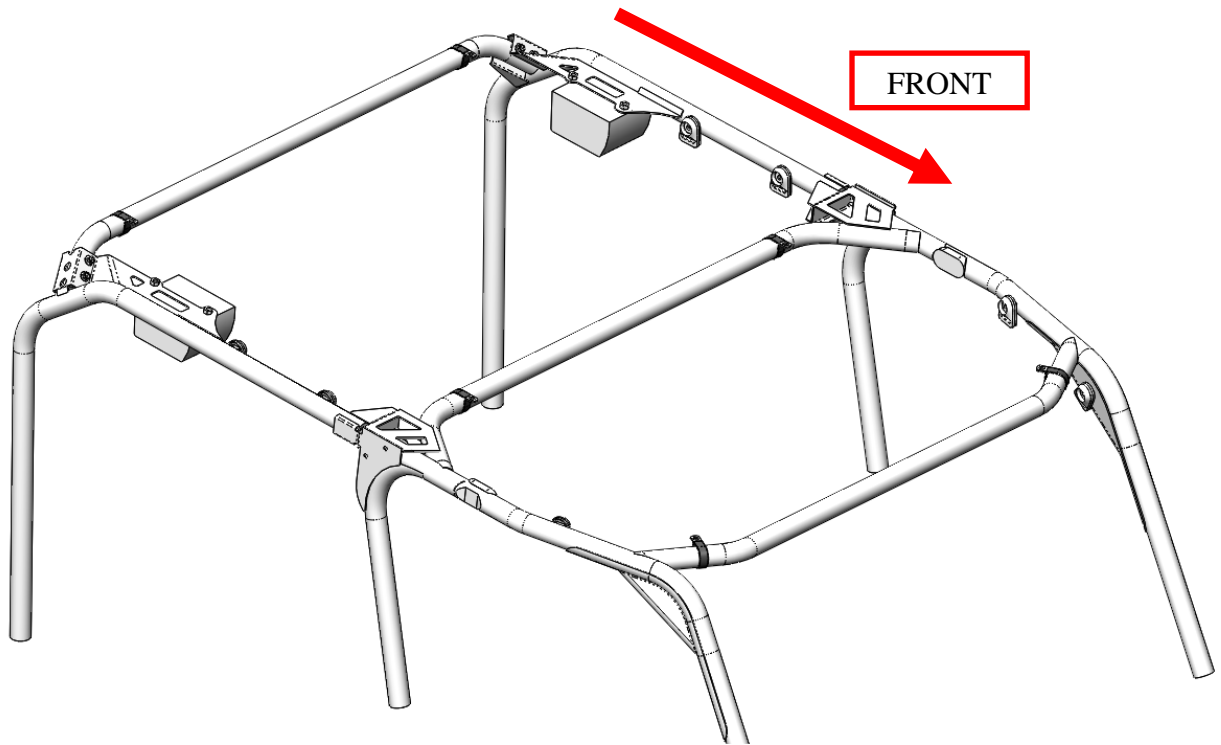


Figure 4: Close up of cage clamp hardware.

2. Spread the clamps by hand and slide them over the cage tubing. Place them on the cage in the approximate locations shown in Figure 5. Note the orientation of the clamp tab. It must line up with the hole, flat against the top, on the correct side of the tubing.



**Figure 5: Approximate clamp locations cage shown.**

3. Using a few assistants, set the *Audio Shade* off-road top on the cage. The top is contoured such that the cage fits inside the grooves on the top. **Note: The top weighs up to 150 lbs. depending on your configuration. Since you will have to lift and reach, it is helpful to have 4 people for this step. See Figure 6.**

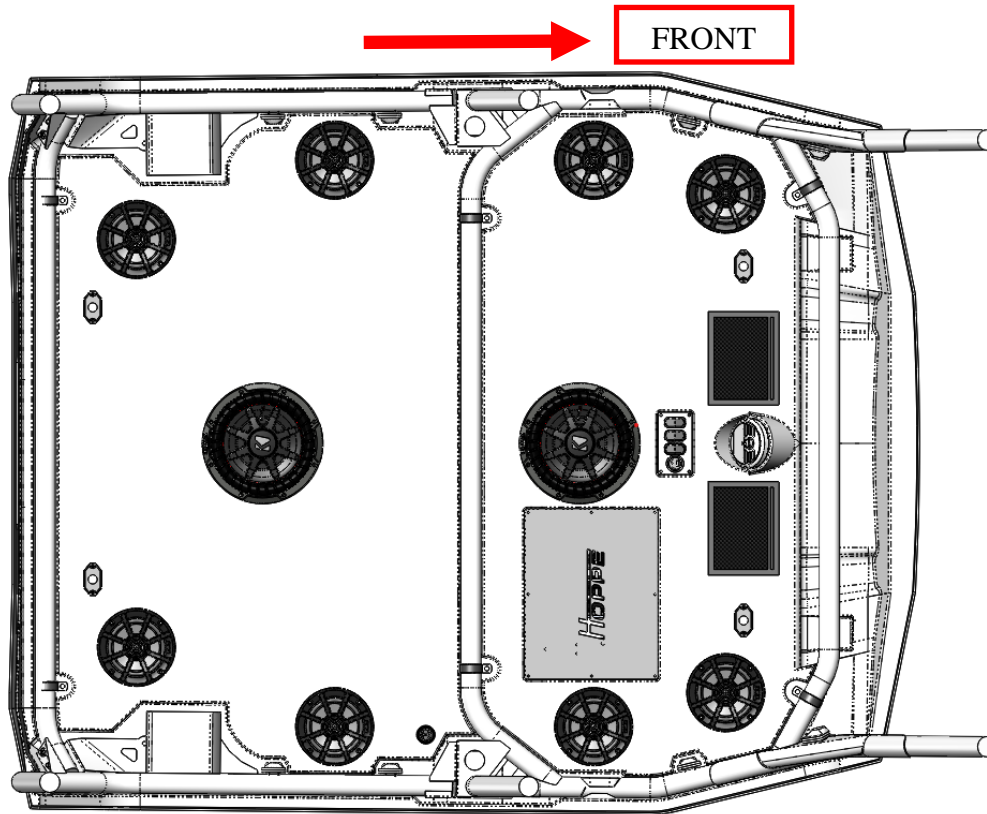
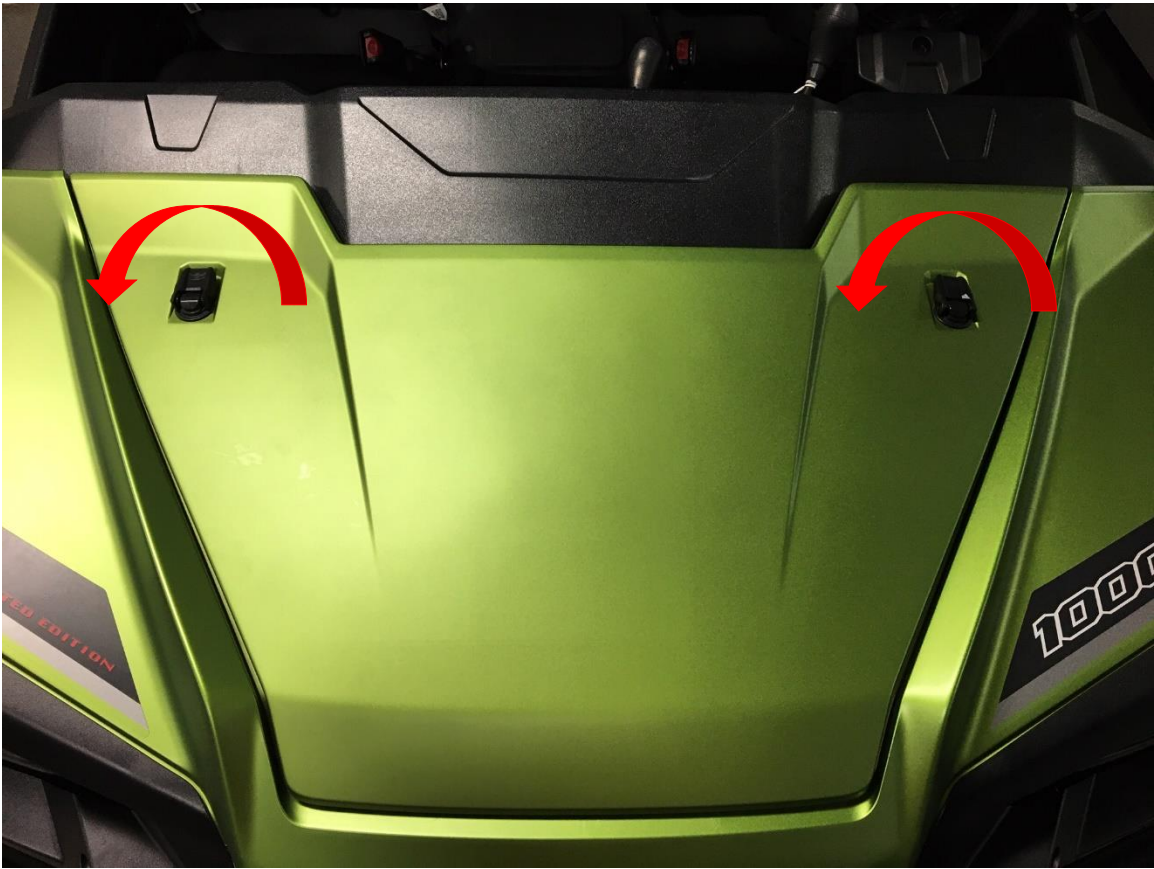


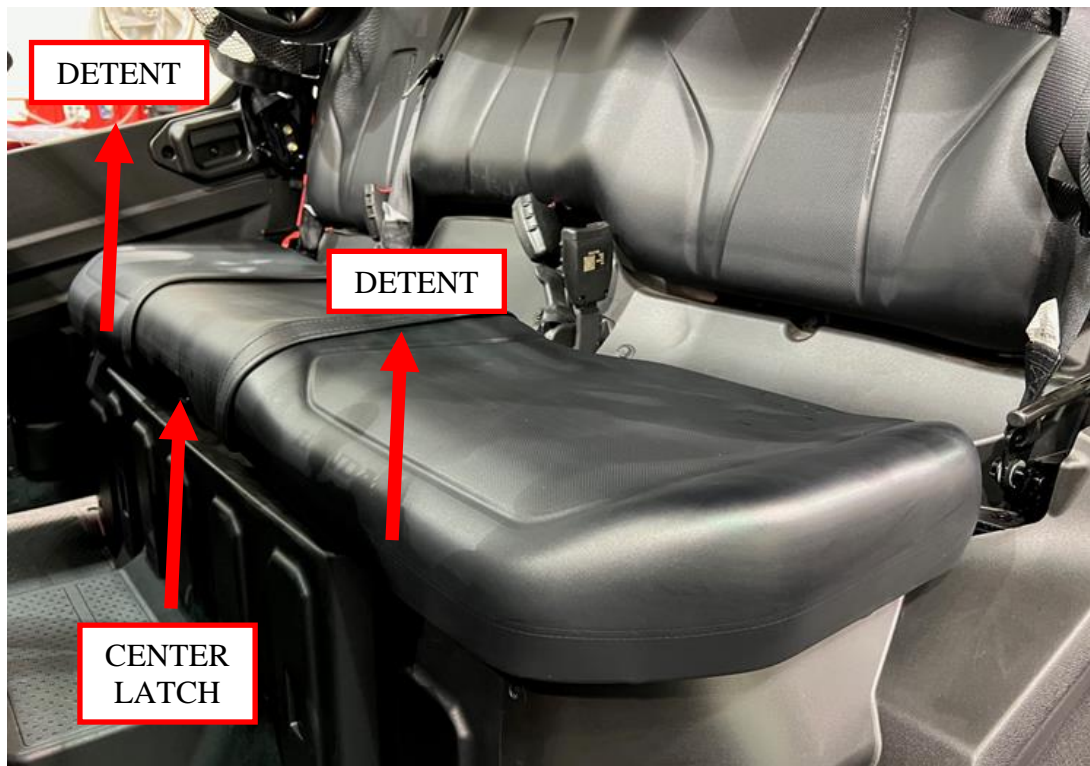
Figure 6: Install the top on the cage.

4. Slide the clamps into position so they line up with the threaded holes in the top. For the two rear clamps and two front clamps, install the 3/8-16 x 1" bolts with washers through both clamp tabs and into the threaded hole in the top. For the center two clamps, install 3/8-16 x 1 1/4" bolts. **Note: if you install the wrong bolt in the wrong location, it may push against the outer skin of the top and damage the surface. Use caution.** Use blue Loctite 243 (medium strength) and torque the bolts to 25 ft.\*lbs. See Figure 4.
5. Remove the radiator hood access panel from the front of the vehicle by lifting and rotating the 1/4 turn clips, lifting the hood, and sliding it towards the front of the vehicle. See Figure 7.



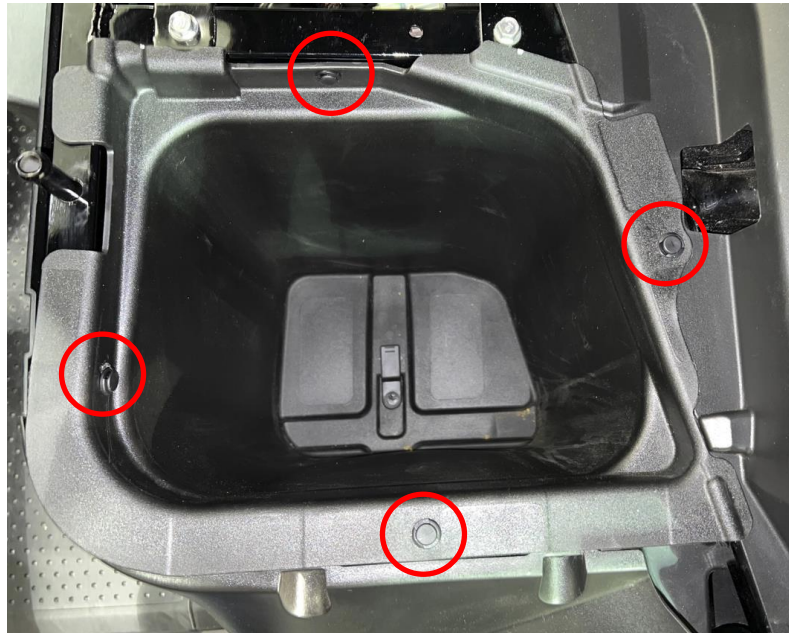
**Figure 7: Remove the radiator hood access panel.**

6. Remove the front seat by releasing the center latch, pulling up around the front edge to release the detents, and unhooking the back edge under the back rests. See Figure 8.



**Figure 8: Remove the front seat.**

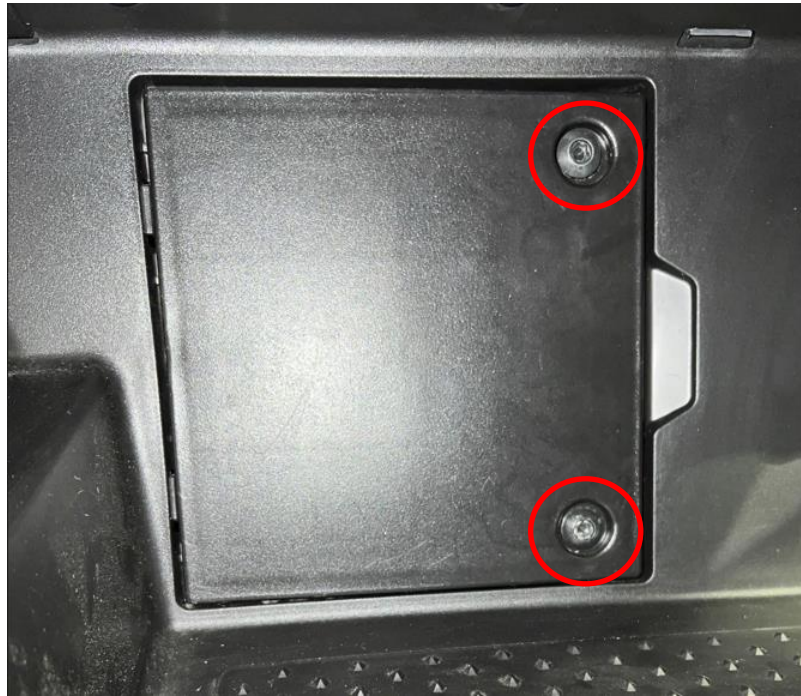
7. Remove the plastic tub from under the driver's side seat. The tub is held in place with 4 plastic rivets. Pry the raised center of the plastic rivet out first, then pry the outside of the rivet. Save the rivets for installation later. See Figure 9.



**Figure 9: Remove the driver's seat tub.**



8. Remove the center under seat cover. There are no fasteners holding it in place. It just lifts off.
9. Remove the access panel located on the bottom of the firewall between the driver and passenger foot wells. There are two 5 mm allen head bolts you must unscrew. See Figure 10.



**Figure 10: Remove the firewall access panel.**

10. Route the chassis wiring harness along the down tube on the driver's side center chassis tube ("B pillar"). The ends with the battery terminals and relay block extend through the plastic trim, into the area under the driver's side seat. Note: The plastic rivet on the trim must be temporarily removed so the relay connector can fit through the opening. See Figure 11.

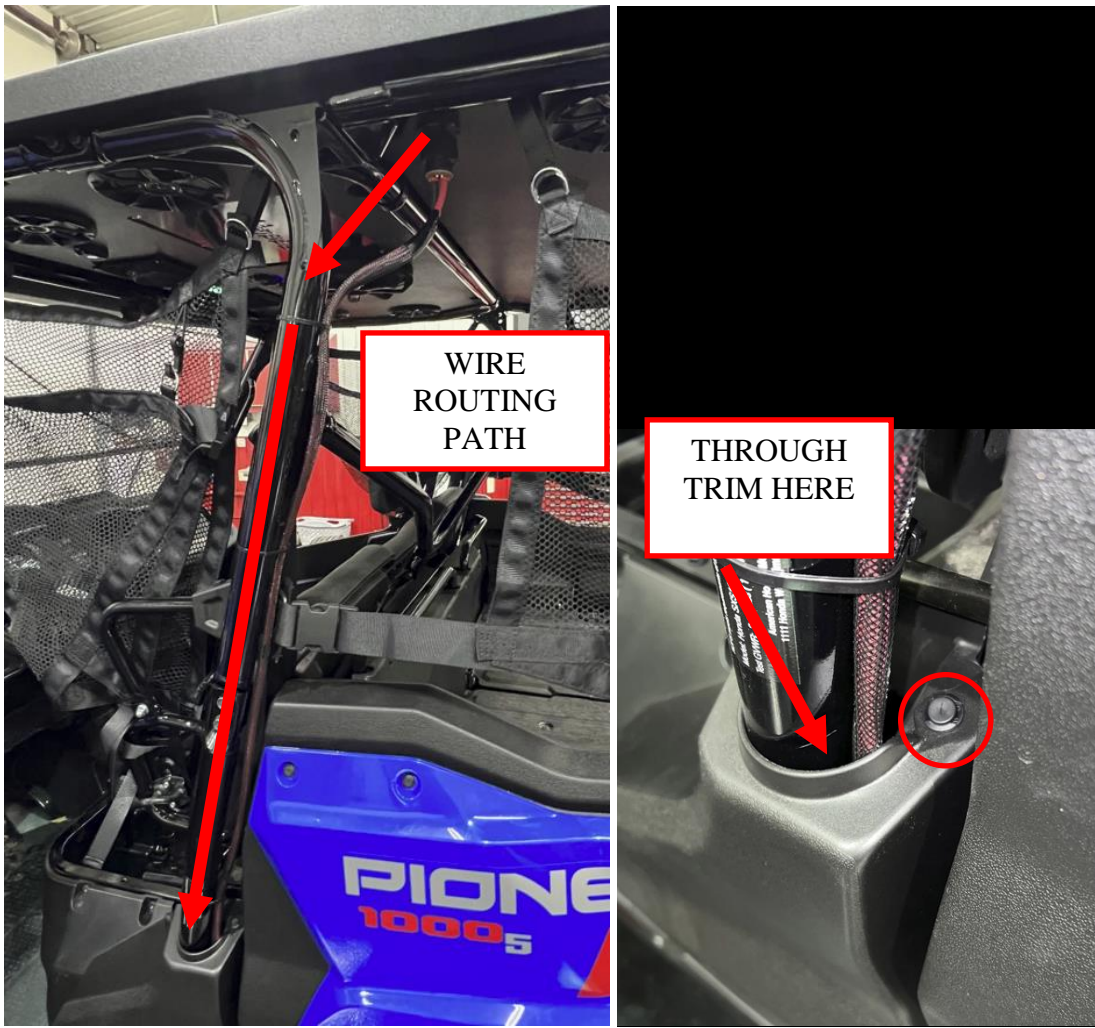
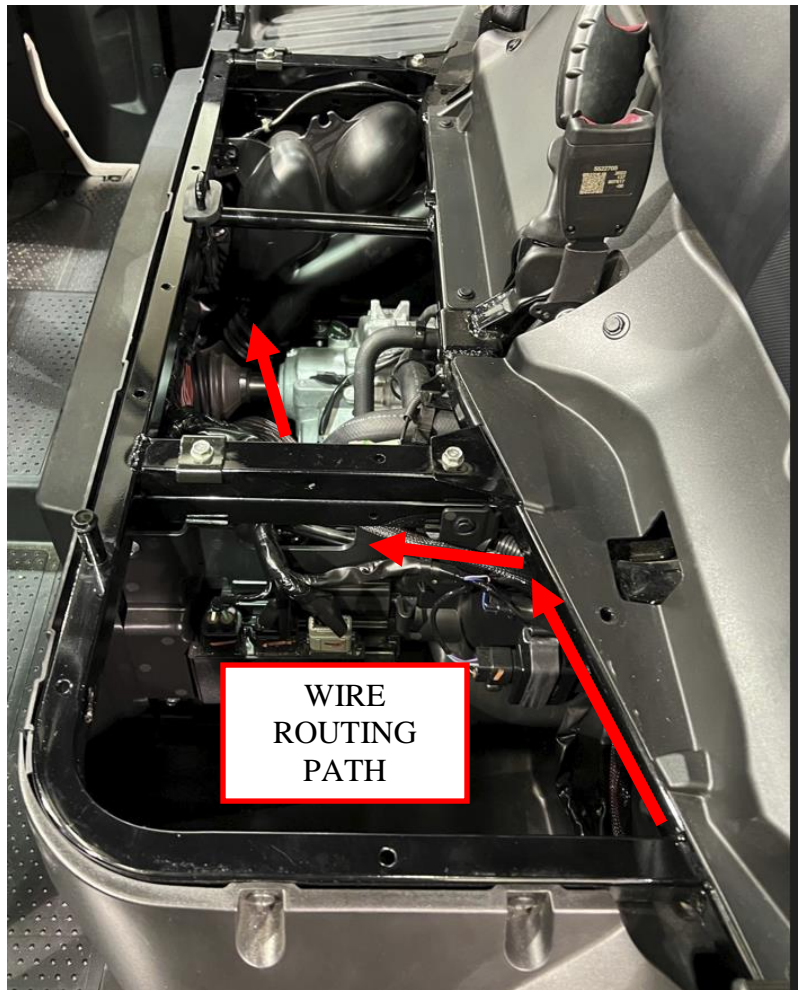


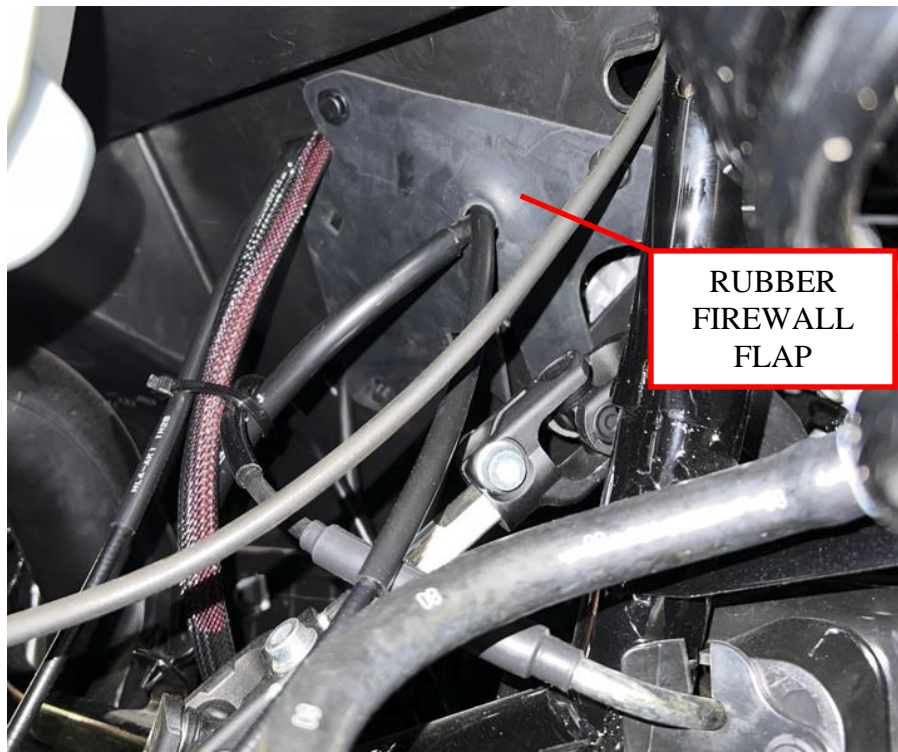
Figure 11: Route the battery cable wiring.

11. Pull the battery connector / relay end of the harness through the under seat divider into the center under seat area. See Figure 12.



**Figure 12: Route the harness through the divider.**

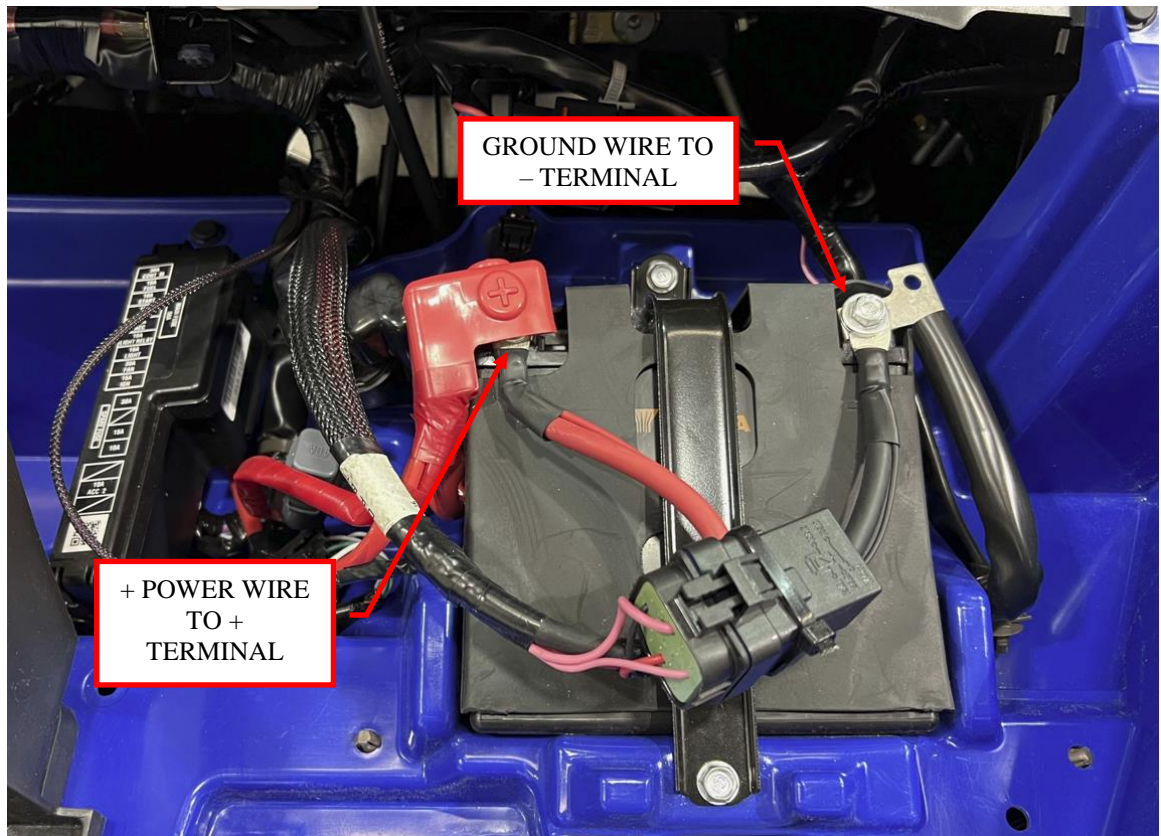
12. Once under the center seat, feed the harness under the center floor board area up to the firewall access panel. Follow the path of the coolant pipes.
13. Reach through the wheel well and feed the harness through the rubber firewall flap up to the under hood battery compartment. See Figure 13.



**Figure 13: Feed the harness up to the under hood area.**

14. Connect the red power wire to the positive terminal of the battery. Connect the black ground wire to the negative terminal of the battery. Use the supplied M6 x 20mm bolts and washers in place of the factory hardware. You may need to use two washers per bolt if the bolt bottoms out on the battery terminal before it tightens the cables. See Figure 14.

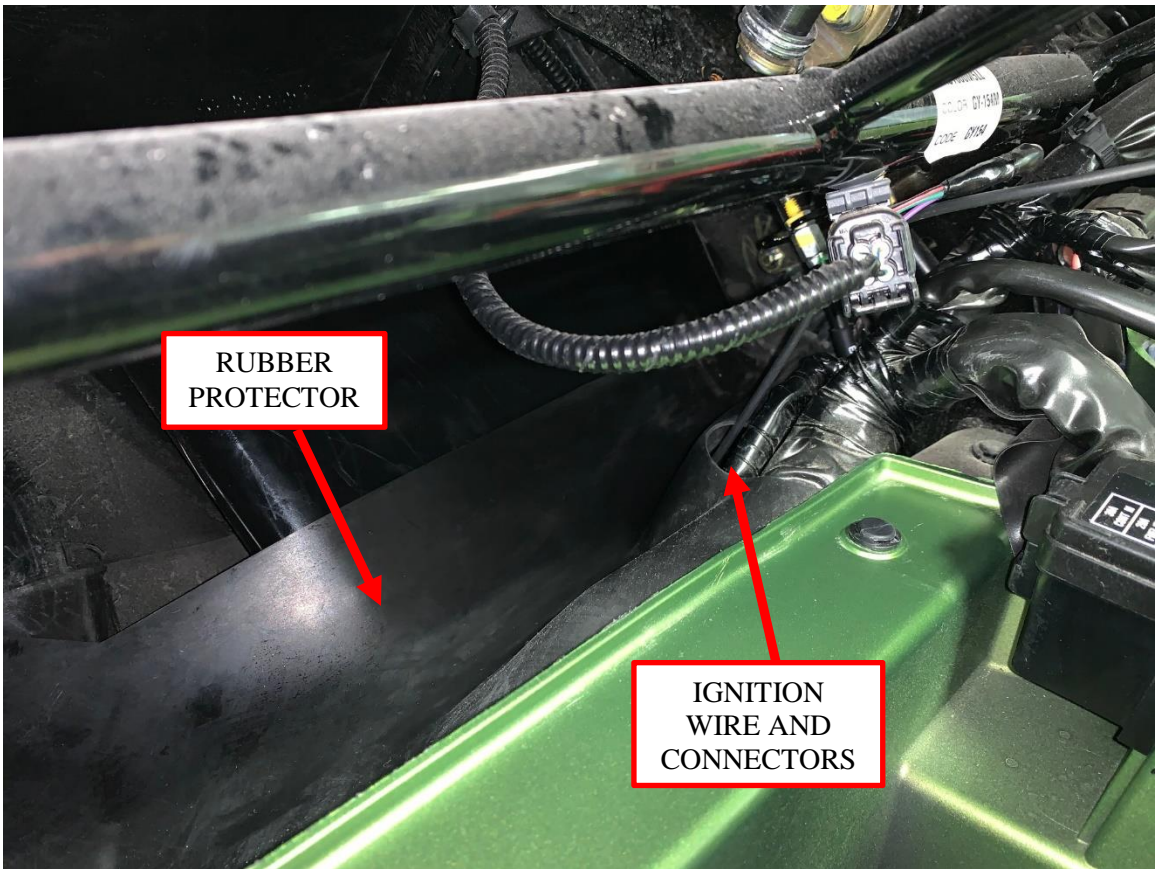




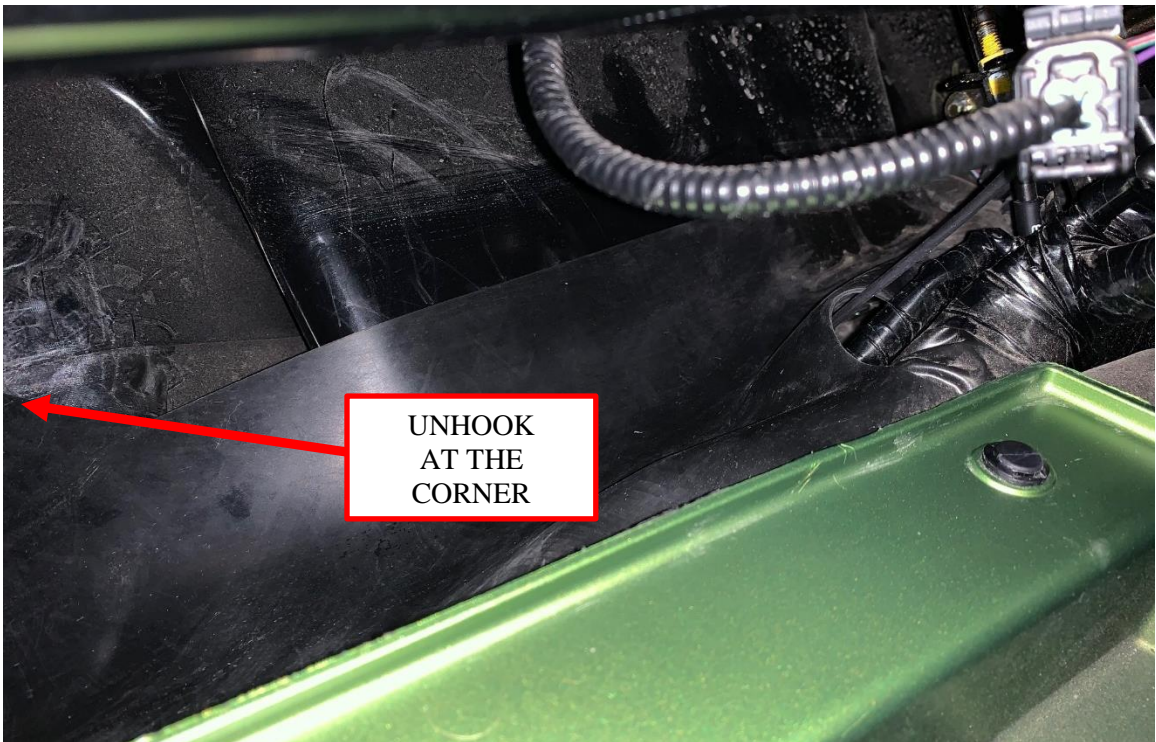
**Figure 14: Attach the main power / ground wire.**

15. Run the pink ignition wire, with the two attached connectors, through the hole in the rubber protector (with the factory wire harness). The connectors are accessible under the rubber protector by lifting the left rear corner of the rubber protector. See Figure 15 and Figure 16.



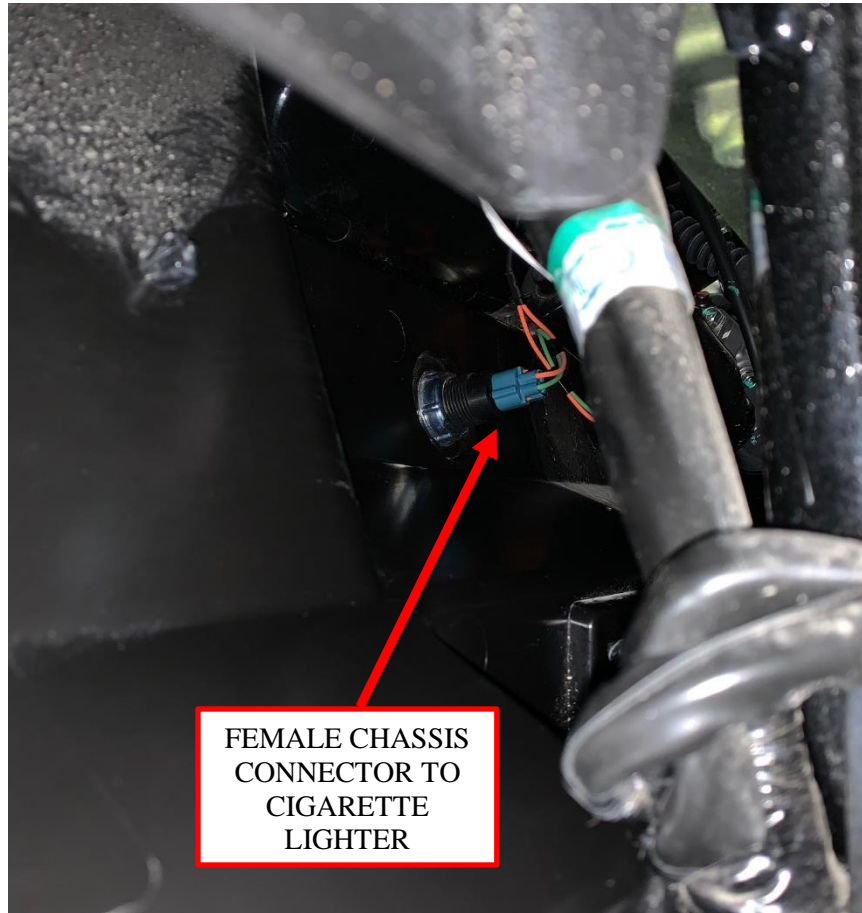


**Figure 15: Ignition wire and connector routing.**



**Figure 16: Rubber protector access location.**

16. The female ignition connector will replace the OEM connector attached to the back of the accessory cigarette lighter as shown in Figure 17. This connection point is accessible through the hood opening under the rubber protector (Figure 17 from wheel well shown for a better view). The male connector on the chassis harness can then be connected to the OEM female connector.



**Figure 17: Connection location for chassis harness connectors.**

17. Connect the Audio Shade roof to the chassis wire harness. Align the connector terminals and rotate the connector housing  $\frac{1}{4}$  turn to lock in place. See Figure 17.



**Figure 18: Align connector terminals and rotate 1/4 turn.**

18. Use zip ties to secure the chassis harness to the roll cage. Secure the wires to the coolant pipes under the seat. Make sure the wires are secured away from any moving suspension components, drive shafts, steering shafts, or hot exhaust. Work your way from the bulk head connector on the top to the battery. Make sure you secure the harness into the corner under the driver's seat so there is room to re-install the tub.
19. Re-install the tub under the driver's seat, the center under seat cover, the seat, the firewall access panel, and the radiator hood panel.
20. You are now ready to enjoy the music, lighting, and shade provided by your *Audio Shade* off-road top. Basic operation works as follows:
  - Turn the vehicle ignition switch on to power up the stereo system.
  - Press the source button on the stereo receiver to select the input source from AM/FM radio, Bluetooth, or Auxiliary.
  - Press and hold the menu button to access the Device Settings menu.
    - Use the Volume knob to change the values for each setting, and press it to confirm the setting.
  - Press and hold the Volume knob to access the Audio Settings menu.
    - Use the Volume knob to change the values for each setting, and press it to confirm the setting.
  - The front and rear light bars can be used with or without the vehicle's ignition switch on. Press the toggle switches to activate each component. **Warning:** extended use of the light bars without the vehicle's charging system functioning will deplete the battery and the engine may not start.
  - To control the interior light color or make them dance to the music, download the Bluetooth app to your iOS or Android device. The app information is included with your Audio Shade and is located in the zipper pocket.

To learn about the more advance features and operation of your stereo, visit the Kicker website links found in SECTION 2 – About your Audio Shade Top of this document.

Thank you for choosing Hoppe *Audio Shade* off-road top for your Honda Pioneer 1000-5 UTV. We hope you enjoy your new sound system, top, and lighting. We invite you, in your travels, to stop by our manufacturing plant in Troup, Texas, for a factory tour and to meet the people who designed and manufactured your Audio Shade off-road top. This will also give you an opportunity to check out our sister companies



and our extensive line of trike conversions, automotive, motorcycle, and power sports accessories.

We believe you will be impressed by what you witness and the people you will meet.