



Made for first. Built to last.

DISCLAIMER:  
PRODUCTS MADE BY L AND W FAB AND MACHINE INC. ARE INTENDED TO FIT YOUR STOCK UTV UNLESS OTHERWISE SPECIFIED. INSTALLING, MODIFYING, OR REMOVING ANY COMPONENTS (FACTORY OR AFTERMARKET) NOT SUPPORTED BY L AND W AND THE INSTRUCTIONS HEREIN WILL VOID YOUR WARRANTY. FOR MORE INFORMATION ON INSTALLATION, WARRANTY, OR PRODUCT USE PLEASE CALL US AT (770) 445-9778

## PRO XP/ PRO R PACKOUT MOUNT PLATE

Fitment: 2019-CURRENT PRO XP  
2022 PRO R



INSTALLATION MANUAL

# Parts List:

Item #	Description	Qty.
1	PACKOUT MOUNT PLATE	1
2	FRONT MOUNT TAB	2
3	7/8" SPACER	2
4	1/2 X 1-3/4 HEX BOLT	2
5	1/2 X 3/4 CARRIAGE BOLT	2
6	1/2 SAE WASHER	2
7	1/2 FLANGE LOCK NUT	4

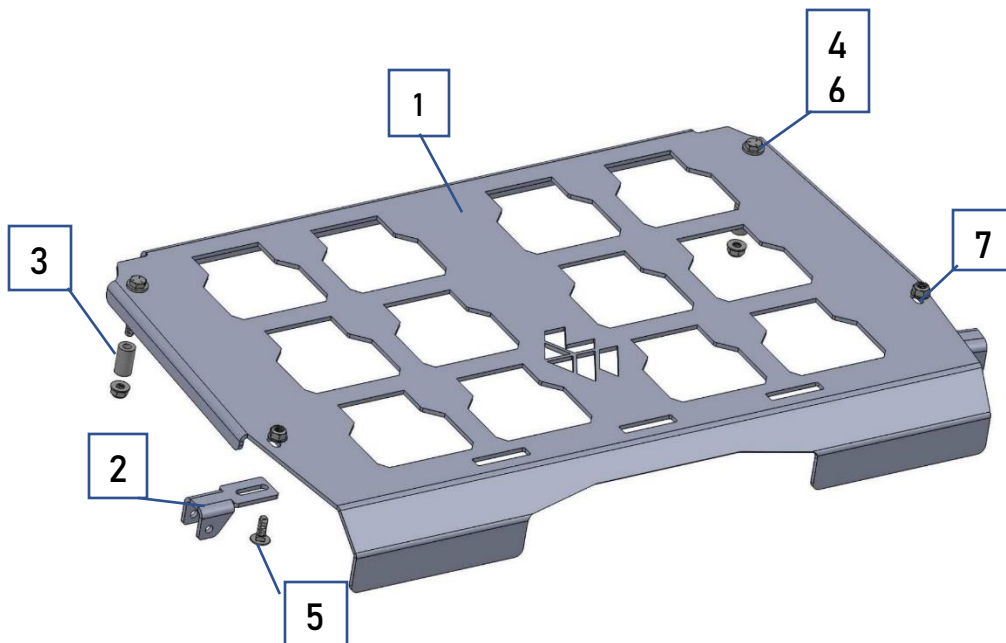

# Installation:

## STEP 1:

Layout parts as shown in the below picture to make sure all parts are present.



## STEP 2:

Remove the (4) T40 Torx bolts and pull out the bed compartment so you can reach both sides of the panel



## STEP 3:

Remove the 2 bolts from the sides of the bed that are in the bottom of the side pockets. On a Pro XP it is the the bolts in the second from firewall slots. On a Pro R it is the bolts in the first slot from firewall.

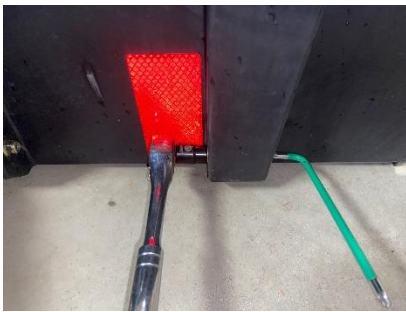

## STEP 4:

Place the 1/2" carriage bolts through the front bracket and bolt through the packout plate as shown in picture leaving the nut loose so the bracket can move forward and back.



### STEP 5:

Place your packout stack onto the packout plate in the order you are planning to stack. Make sure the packouts are fully snapped into lock position. This is to make sure of clearance between firewall and boxes. With the packouts locked onto the plate, position the plate into the bed and align in the center driver to passenger side, and leave about  $\frac{1}{4}$ " gap between the packout and firewall. Place the factory bolts and nuts you removed back through the bed, making sure the front brackets are lined up. Once happy with placement, using a  $\frac{5}{16}$ " Drill bit, mark and drill the 2 rear holes. (It may be necessary to remove the packout to drill)



### STEP 6:

With the holes drilled, place the (2)  $\frac{1}{4}$ " x 1-3/4" bolts through the rear holes with a washer on top. Use the supplied spacer between the packout plate and the base of the bed, and flange nut on bottom.

### STEP 7:

With everything in place, and bolts started, verify fitment with your packout. Once verified, tighten all the bolts.

**THANK YOU FOR CHOOSING L&W FAB!**