



INSTALLATION INSTRUCTIONS

Winch Mount

Part Number: 101434

Application: 2018 Maverick Trail

GENERAL SAFETY PRECAUTIONS

Your safety, and the safety of others, is very important. To help you make informed decisions about safety, we have provided installation and operating instructions and other information on labels and in this guide. This information alerts you to potential hazards that could hurt you or others. It is not possible to warn you about all potential hazards associated with this product, you must use your own good judgment.

CARELESS INSTALLATION AND OPERATION CAN RESULT IN SERIOUS INJURY OR EQUIPMENT DAMAGE. READ AND UNDERSTAND ALL SAFETY PRECAUTIONS AND OPERATING INSTRUCTIONS BEFORE INSTALLING AND OPERATING THIS PRODUCT.

This guide identifies potential hazards and has important safety messages that help you and others avoid personal injury or death. WARNING and CAUTION are signal words that identify the level of hazard. These signal words mean:

▲WARNING signals a hazard that could cause serious injury or death, if you do not follow recommendations. ▲CAUTION signals a hazard that may cause minor to moderate injury, if you do not follow recommendations.

This guide uses NOTICE to call attention to important mechanical information, and Note: to emphasize general information worthy of special attention.

▲ WARNING

IMPACT AND MOVING PARTS ENTANGLEMENT HAZARD

Failure to observe these instructions could lead to severe injury or death

- **Always** take time to fully read the Instructions and/or Operations Guide, and/or Basic Guide to Winching Techniques, in order to understand your winch and its operations.
- **Always** use extreme caution when drilling on any vehicle. Make sure that all fuel lines, brake lines, electrical wires, and other objects are not punctured or damaged when/if drilling on the vehicle. Thoroughly inspect the area to be drilled (on both sides of material) prior to drilling, and relocate any objects that may be damaged. Failure to inspect the area to be drilled may result in vehicle damage, electrical shock, fire or personal injury.
- **Always** wear safety glasses when installing this kit. A drilling operation will cause flying metal chips. Flying chips can cause eye injury.
- **Always** use extreme caution when cutting and trimming during fitting.
- **Always** remove jewelry and wear eye protection.
- **Never** lean over battery while making connections.
- **Never** route electrical cables:
 - o Across any sharp edges.
 - o Through or near moving parts.
 - o Near parts that become hot.
- **Always** insulate and protect all exposed wiring and electrical terminals.
- **Always** install terminal boots as directed in installation instructions.
- **Always** use appropriate and adequate care in lifting components into place.
- **Always** insure components will remain secure during installation and operation.
- **Always** tighten all nuts and bolts securely, per the installation instructions.
- **Always** perform regular inspections and maintenance on the plow mechanism, fasteners, cable and related hardware.
- **Always** replace all worn or damaged parts before operating.
- **Never** operate this WARN product with damaged or missing parts.

Read installation and operating instructions thoroughly.

WARN INDUSTRIES, INC. 12900 S.E. Capps Road,
Clackamas, OR USA 97015-8903, 1-503-722-1200, FAX: 1-503-722-3000
Customer Service: 1-800-543-9276
Dealer Locator Service: 1-800-910-1122
International Fax: 1-503-722-3005

⚠ CAUTION

MOVING PARTS ENTANGLEMENT HAZARD

Failure to observe these instructions could lead to minor or moderate injury

- **Always** take time to fully read and understand the installation and Operations Guide included with this product.
- **Never** operate this product if you are under 16 years of age.
- **Never** operate this product when under the influence of drugs, alcohol or medications.

Read installation and operating instructions thoroughly.

NOTICE

EQUIPMENT DAMAGE

- **Never** tow vehicle by attaching a tow bar to the eyelets on the bumper.
- **Never** attach tow bars directly to the bumper. Damage to bumper may occur. WARN bumpers are not designed to be used for flat towing. Consult with the manufacturer of your tow bar system for the proper vehicle tow bar brackets..

Read installation and operating instructions thoroughly.

MAINTENANCE / CARE

1. Inspect all parts on the winch, winch mount, and related hardware prior to each use. Replace all hardware that appears rusted or deformed.
2. Inspect all nuts and bolts on the winch, winch mount and related hardware prior to each use. Tighten all nuts that appear to be loose. Stripped, fractured, or bent bolts or nuts need to be replaced.
3. Check all cables prior to use. Replace cables that look worn or frayed.
4. Check all moving or rotating parts. Remove debris that may inhibit the part from moving freely.

TABLE OF CONTENTS

Maintenance/Care.....	page 2
Tools Required.....	page 2
Torque Specifications.....	page 3
Parts List.....	page 3
Installation.....	page 4-5

TOOLS REQUIRED

- Metric wrenches
- Metric sockets
- Fine tooth reciprocating saw
- Small disk sander

PARTS LIST

ID No.	Item No.	Description	Qty.
A1	101433	WINCH PLATE	1
B1	79583	M10 FLANGE HEAD BOLT	2
B2	69807	M10 LOCK NUT	2
B3	220026	FLAT WASHER	2
B4	85802	M10 SOCKET HEAD BOLT	2

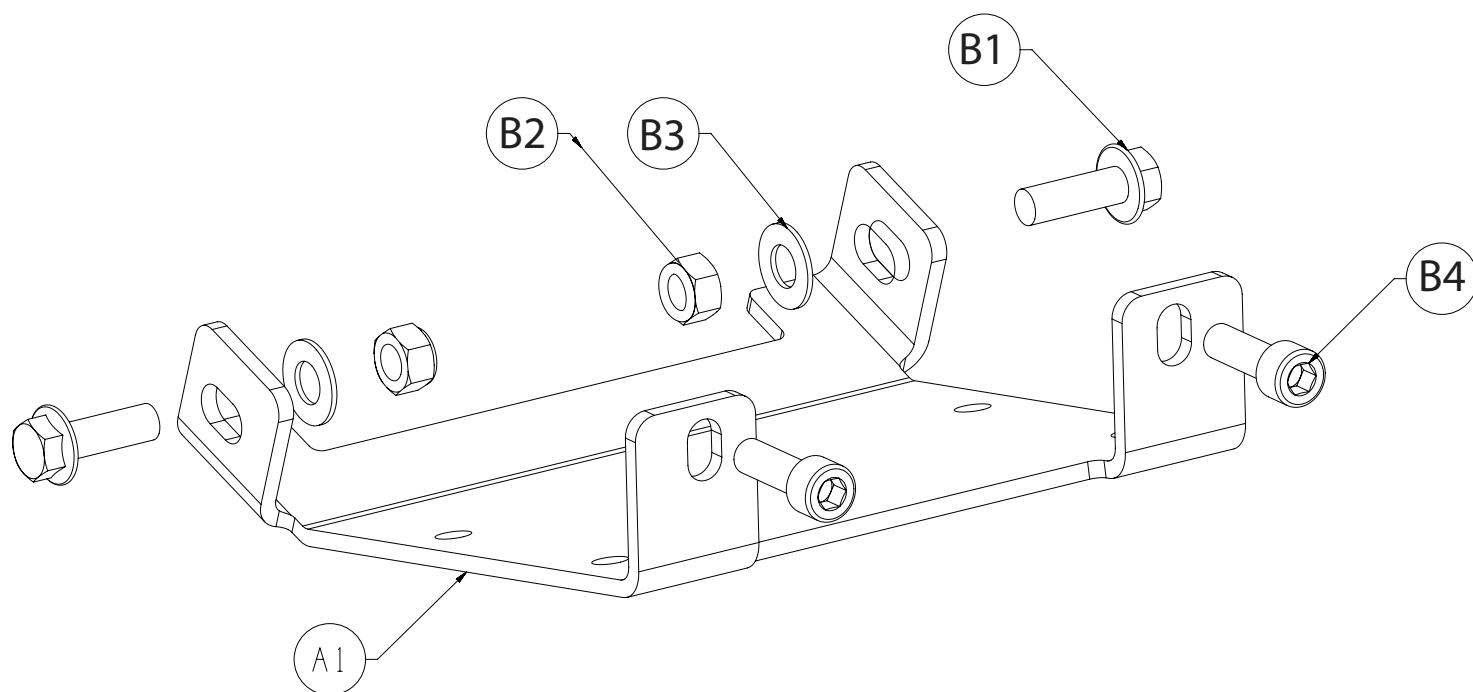

TORQUE SPECIFICATIONS

Please use the recommended torque specifications when assembling this product unless otherwise specified in the instructions.

FASTENER SIZE		FASTENER TORQUE		FASTENER SIZE		FASTENER TORQUE	
	lb-ft	(N.m)		lb-ft	(N.m)		(N.m)
1/4"	8	(11)	M4	(2)	3		
5/16"	17	(23)	M5	(4.5)	6		
3/8"	30	(40)	M6	(7.5)	10		
7/16"	48	(66)	M8	(18)	25		
1/2"	74	(100)	M10	(37)	50		
9/16"	106	(144)					
5/8"	148	(200)					
3/4"	269	(364)					

INSTALLATION INSTRUCTIONS

1. Remove the factory skid plate by removing the two lower hex head bolts, six torx head screws (three on each side - holding tubes to skid plate) and two (one each side) hex head side bolts.

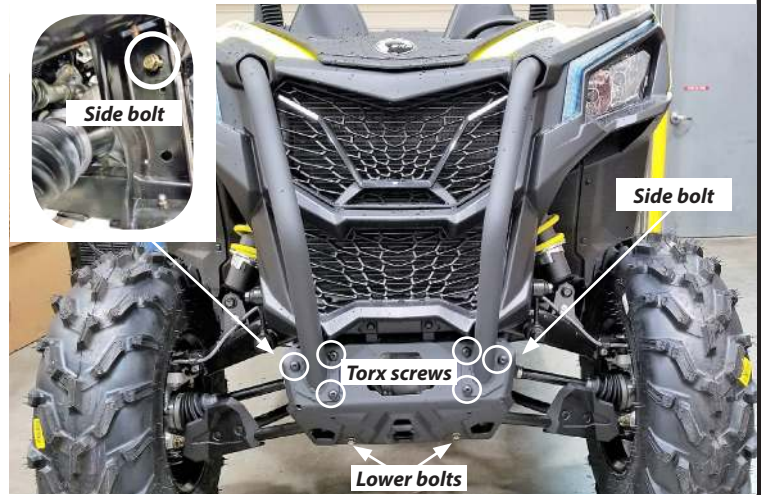

Figure 1

Figure 2 shows skid plate removed.



Figure 2

2. Place winch on top of winch mount (A1).
3. Line up winch feet with the four holes on mount.
4. Secure winch to winch mount following instructions and using hardware found in your winch kit.

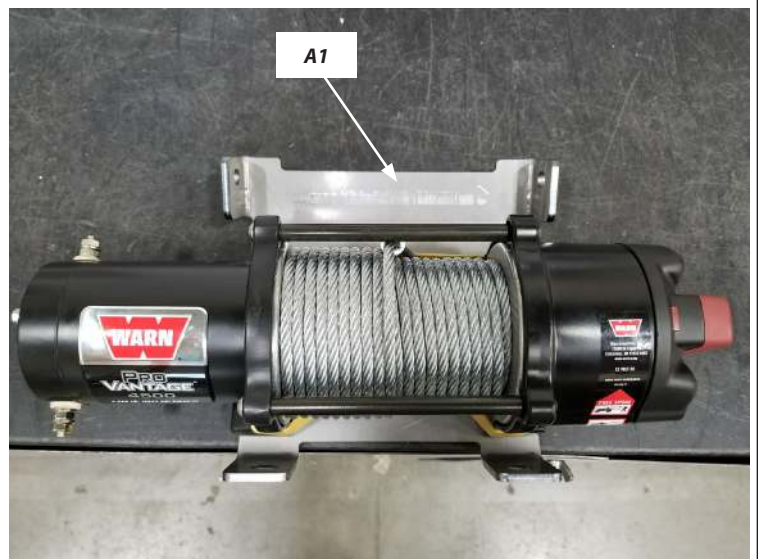

Figure 3

INSTALLATION INSTRUCTIONS

5. Place winch mount/winch assembly on vehicle and secure using M10 hardware B1, B2 and B3 (each side). Refer to exploded view on page 3.



Figure 4

6. Place factory skid plate on vehicle and secure with two side bolts previously removed in step 1.

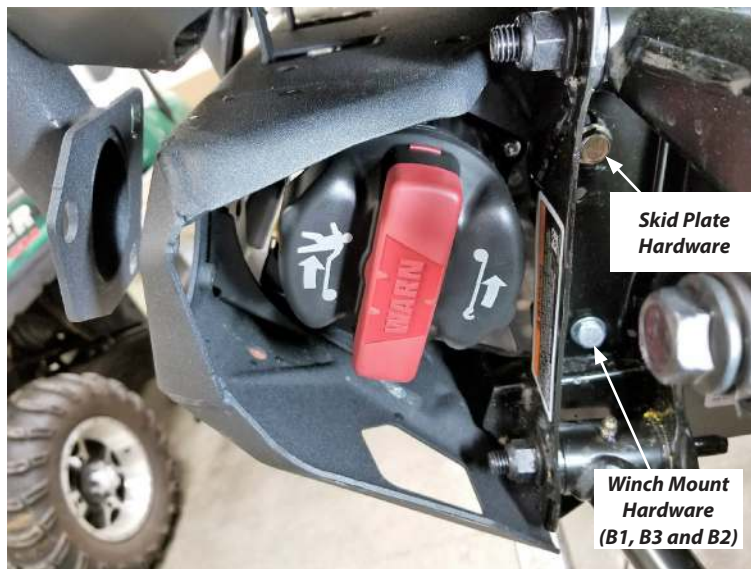

Figure 5

7. Reinstall the two lower bolts to skid plate.
- 8.. Reinstall the six torx head screws to secure tubes to skid plate.
8. Install fairlead using the two bolts (B4) found in this kit and the nuts from winch kit.
9. Installation is now complete.



Figure 6