



# INSTALLATION INSTRUCTIONS

## Winch Mounting Kit

Winch Mount Kit: 70207

Application: **Kawasaki Brute Force**

Your safety, and the safety of others, is very important. To help you make informed decisions about safety, we have provided installation and operating instructions and other information on labels and in this guide. This information alerts you to potential hazards that could hurt you or others. It is not possible to warn you about all potential hazards associated with this product, you must use your own good judgment.

**CARELESS INSTALLATION AND OPERATION CAN RESULT IN SERIOUS INJURY OR EQUIPMENT DAMAGE. READ AND UNDERSTAND ALL SAFETY PRECAUTIONS AND OPERATING INSTRUCTIONS BEFORE INSTALLING AND OPERATING THIS PRODUCT.**

This guide identifies potential hazards and has important safety messages that help you and others avoid personal injury or death. **WARNING** and **CAUTION** are signal words that identify the level of hazard. These signal words mean:

**▲WARNING** signals a hazard that *could* cause serious injury or death, if you do not follow recommendations. **▲CAUTION** signals a hazard that *may* cause minor to moderate injury, if you do not follow recommendations.

This guide uses **NOTICE** to call attention to important mechanical information, and **Note**: to emphasize general information worthy of special attention.

### ▲ WARNING

#### INJURY HAZARD

**Failure to observe these instructions could lead to severe injury or death.**

- ❑ **Always** use extreme caution when drilling on any vehicle. Make sure that all fuel lines, brake lines, electrical wires, and other objects are not punctured or damaged when / if drilling on the vehicle. Thoroughly inspect the area to be drilled (on both sides of material) prior to drilling, and relocate any objects that may be damaged. Failure to inspect the area to be drilled may result in vehicle damage, electrical shock, fire or personal injury.
- ❑ **Always** wear safety glasses when installing this kit. A drilling operation will cause flying metal chips. Flying chips can cause eye injury.
- ❑ **Always** use extreme caution when cutting and trimming during fitting.
- ❑ **Always** remove jewelry and wear eye protection.
- ❑ **Never** lean over battery while making connections.
- ❑ **Never route electrical cables:**
  - Across any sharp edges.
  - Through or near moving parts.
  - Near parts that become hot.
- ❑ **Always** insulate and protect all exposed wiring and electrical terminals.
- ❑ **Always** install terminal boots as directed in installation instructions.
- ❑ **Always** use appropriate and adequate care in lifting components into place.
- ❑ **Always** insure components will remain secure during installation and operation.
- ❑ **Always** tighten all nuts and bolts securely, per the installation and operation.
- ❑ **Always** perform regular inspections and maintenance on the winch, winch mount and related hardware.
- ❑ **Never** operate this **WARN** product with damaged or missing parts.

 <b>Caution</b>
<b>Moving Parts Entanglement Hazard</b>
<b>Failure to observe these instructions could lead to minor or moderate injury.</b>
<input type="checkbox"/> <b>Always</b> take time to fully read and understand the installation and Operations Guide included with this product. <input type="checkbox"/> <b>Never</b> operate this product if you are under 16 years of age. <input type="checkbox"/> <b>Never</b> operate this product when under the influence of drugs, alcohol or medications.
<b>Read installation and operating instructions thoroughly.</b>

<b>Notice</b>
<b>Equipment Damage</b>
<input type="checkbox"/> <b>Always</b> refer to the Installation and Specification Guide, supplied in the winch kit, for all wiring schematics and specific details on how to wire this WARN product to your vehicle.
<b>Read installation and operating instructions thoroughly.</b>

**Table of Contents**

I. Parts List ..... 3

II. Tools Required ..... 3

III. Installation ..... 4

IV. Specific Wiring Instructions ..... 6

V. Maintenance/Care ..... 10

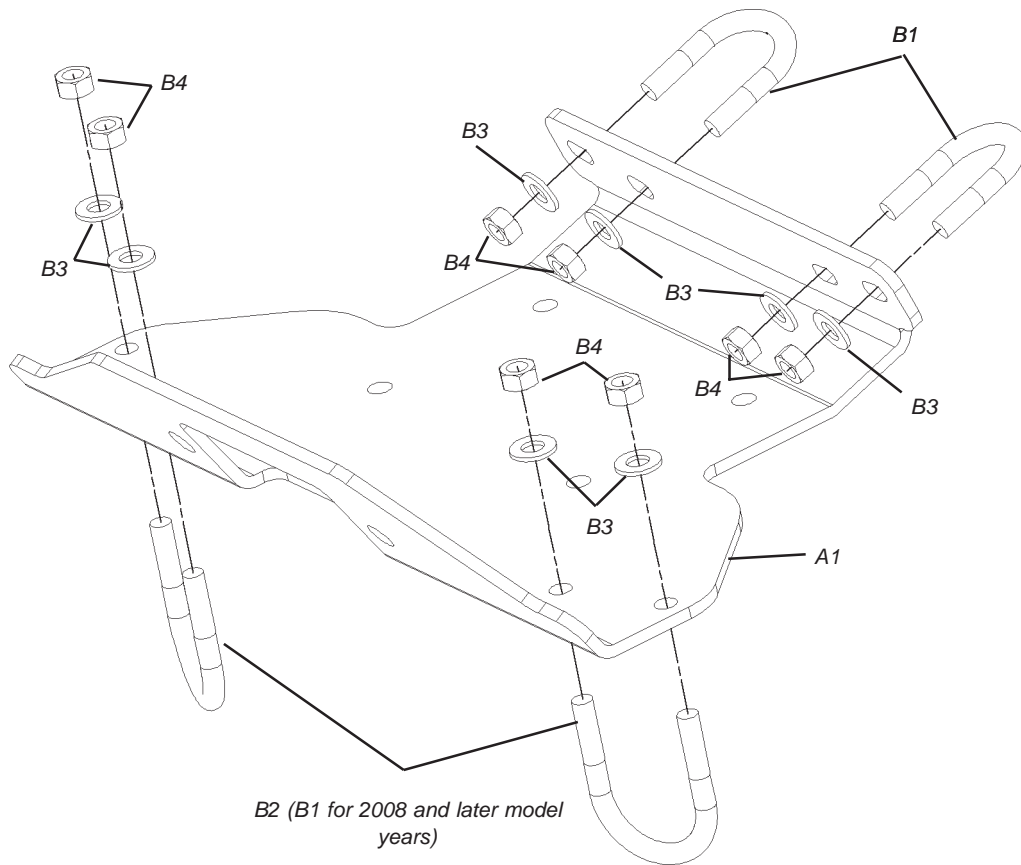

## I. Parts List

<u>Ref</u>	<u>Description</u>	<u>Qty</u>
A1	Winch Mounting Plate	1
B1	5/16-18 x 1 1/8" x 1 3/4" U-bolt	4
B2	5/16-18 x 1 1/2" x 2 3/16" U-bolt	2
B3	5/16" Flat Washer	8
B4	5/16-18 Lock Nut	8
	1/4-20 x 1" x 1 1/2" U-bolt	2
	1/4" Flat Washer	4
	1/4-20 Lock Nut	4

## II. Tools Required

- Ratchet
- Sockets: 10mm, 1/2"
- Wrenches: 1/2"

### III. INSTALLATION

1. Loosen the front bottom skid plate by removing the front two 6mm bolts, Figure 1. Keep the 6mm bolts for reinstallation of the skid plate. Skid plate will not be removed from vehicle, only will be rotated down. This will allow room for winch plate installation.

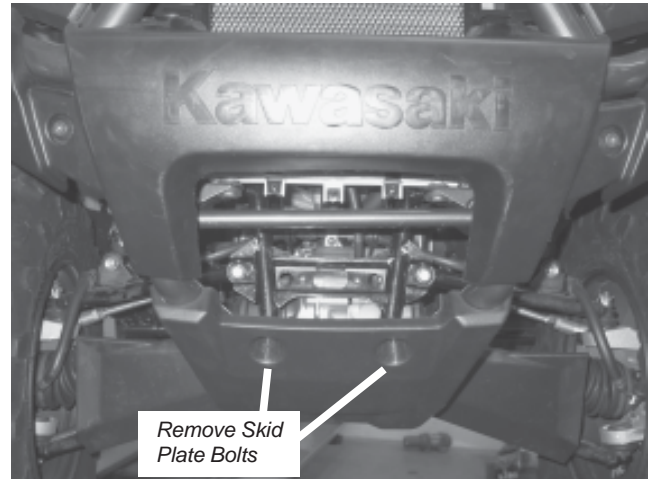

Figure 1 Loosen Front Skid Plate

2. Place winch mounting plate (A1) sideways in between the front tube guards and vehicle frame, Figure 2.

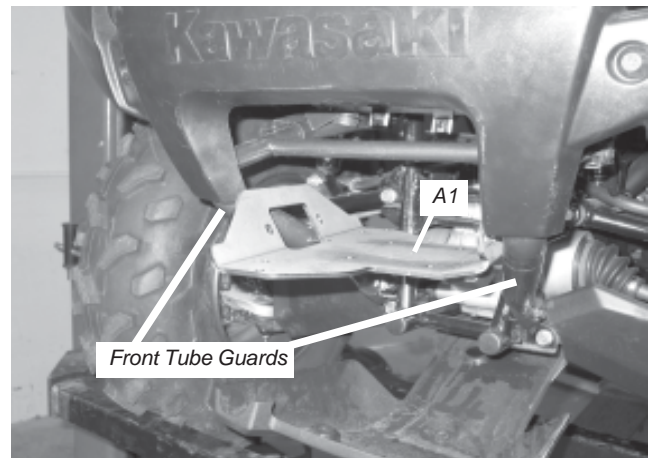

Figure 2 Install Winch Mounting Plate

3. Rotate winch mounting plate (A1), Figure 3. Tilt winch mount forward by raising rear face such that the front right corner clears the front tube guard, Figure 3.

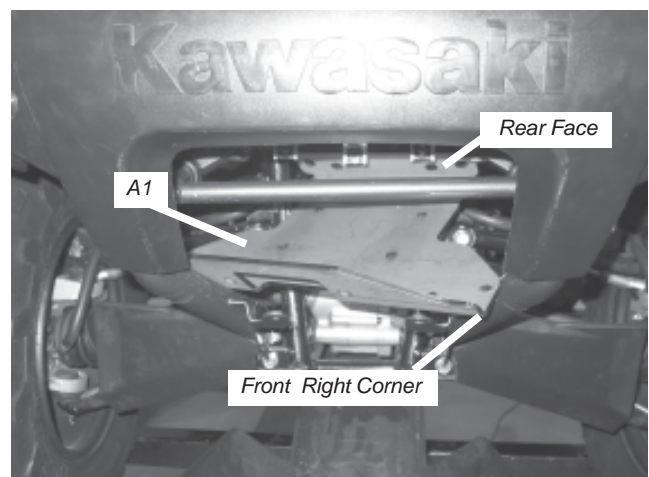

Figure 3 Rear Support Mount Bracket

4. Rotate the mounting plate (A1) into location, Figure 4. Center the plate between the two front tube guards.
5. Attach the mounting plate (A1) by sliding the supplied 5/16" U-bolts (B1) and (B2) around the tubes and through the plate, Figure 5. Fasten the U-bolts with the supplied washers (B3) and nuts (B4), ensuring that the plate sits flush against the front and rear contact surfaces. Tighten all 5/16" fasteners to the recommended torque value of 12 N-m (9 ft-lbs).

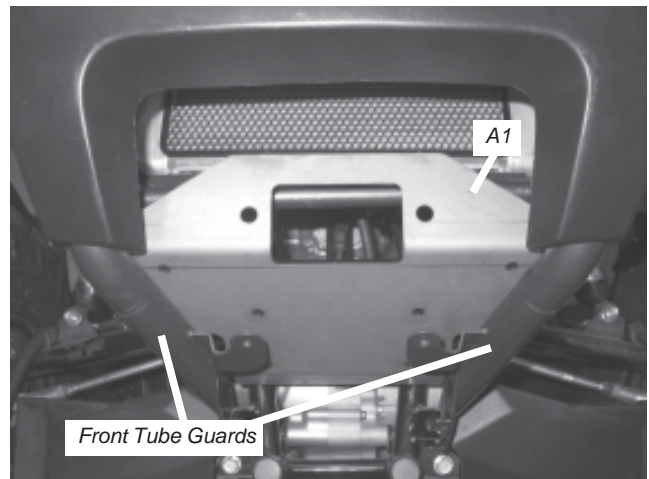

Figure 4 Place Winch Mounting Plate into Location

**Note: For 2008 and later model years B2 u-bolt will be replaced with an additional quantity (2) of B1 u-bolt; (Frame tube size is smaller on 2008 and later model years and smaller u-bolt allows for a more secure fit to frame).**

6. Install winch from the left side of the vehicle, as sitting on the vehicle, Figure 6. Fasten winch with hardware supplied with the winch. Mount the winch so that the motor faces the right side of the vehicle. Tighten the bolts to a recommended torque of 17 N-m (12 ft-lb).

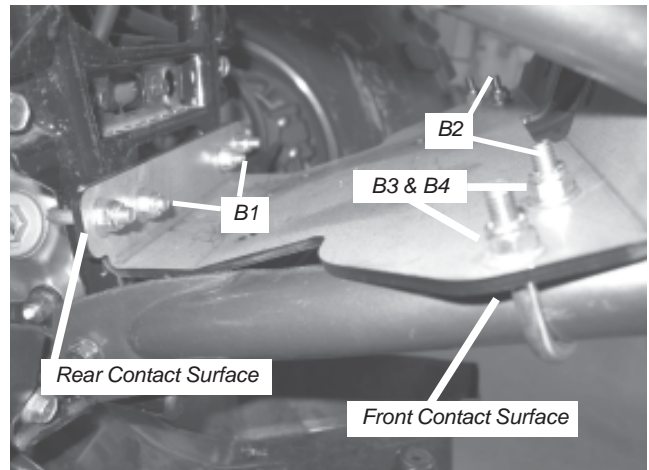

Figure 5 Fasten Winch Mounting Plate

Also attach roller fairlead to the winch mounting plate, Figure 6, using two hardware provided in the winch kit. See instructions included in winch kit for recommended torque.

7. Switch the winch clutch to freespool. Manually feed the winch cable through the roller fairlead. Attach the clevis hook to the end cable loop, Figure 7. Reinstall front skid plate with original hardware from step 1 and securely tighten.
8. Complete the winch installation as described in the winch installation and specification guide that came with the winch.

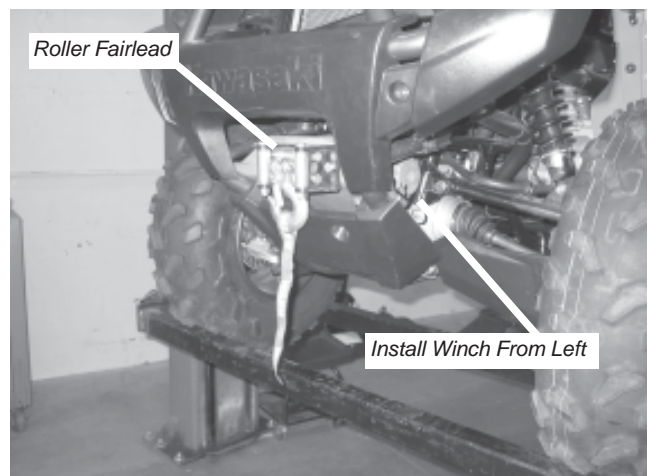

Figure 6 Install Winch and Roller Fairlead

**Winch and winch mount installation is now complete and should look like Figure 7. Proceed to section IV, entitled "Specific KVF750 Wiring Instructions".**

**⚠ WARNING**

FAILURE TO SECURELY TIGHTEN ALL BOLTS ON THE WINCH PLATE, WINCH, AND FAIRLEAD CAN RESULT IN PRODUCT FAILURE WHICH MAY RESULT IN VEHICLE DAMAGE AND OPERATOR INJURY OR DEATH. DOUBLE CHECK THAT ALL BOLTS ARE SECURELY TIGHTENED PRIOR TO USE.

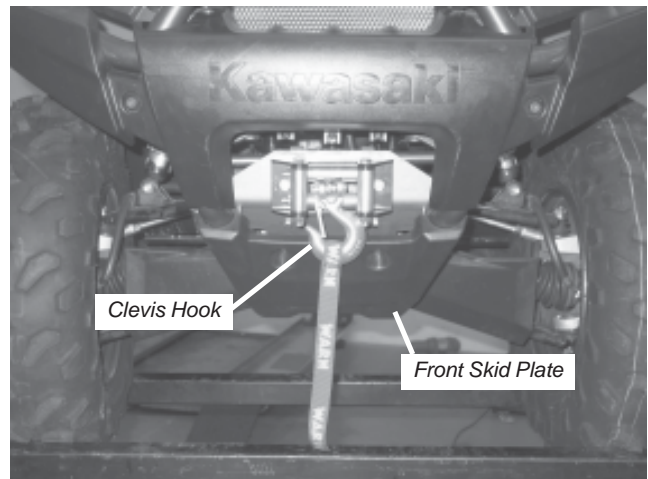

Figure 7 Complete Winch Installation

#### IV. Specific KVF750 Wiring Instructions

**Notice**

IT SHOULD BE NOTED THAT THE FOLLOWING INSTRUCTIONS ARE UNIT SPECIFIC. THE FOLLOWING INSTRUCTIONS SHOULD BE REFERRED TO AS REFERENCE INSTRUCTIONS TO ASSIST WIRING THE WINCH FROM THE INSTALLATION AND SPECIFICATION GUIDE SUPPLIED IN THE WINCH KIT.

**⚠ WARNING**

AVOID ALL MOVING AND POTENTIALLY HOT COMPONENTS OF ATV WHEN ROUTING ELECTRICAL CABLES. AVOID AREAS WHERE THE WIRING COULD BE PINCHED WHEN COMPONENTS ARE REINSTALLED. FAILURE TO DO SO CAN RESULT IN PRODUCT FAILURE WHICH CAN LEAD TO VEHICLE DAMAGE AND OPERATOR INJURY OR DEATH.

#### 1. Wiring Contactor Installation

- a. Remove seat shown in Figure 11.
- b. Remove air filter cover shown in Figure 12.
- c. Remove the battery cover shown in Figure 13.
- d. Remove cover under handlebars shown in Figure 14.



Figure 11

- e. Remove side pocket panel shown in Figure 15.
- f. Remove side panel shown in Figure 16.
- g. Secure contactor with supplied U-bolts, washer and nuts, supplied in winch mounting kit, see Figure 17.

**Note: Do not over tighten U-bolts, this may damage the contactor.**



Figure 12

- h. Route the red and black battery electrical cables in-between the air box and then around the battery, shown in Figure 18 and 19.
- i. Route the blue and yellow cables along frame as shown in Figure 17.

**Note: For 2008 and later model years a conduit has been factory supplied on the ATV running from the winch mount area to the contact mount area next to air box. Blue and yellow cables can be routed through this conduit from winch to contactor. Conduit may be trimmed as required to ease installation.**

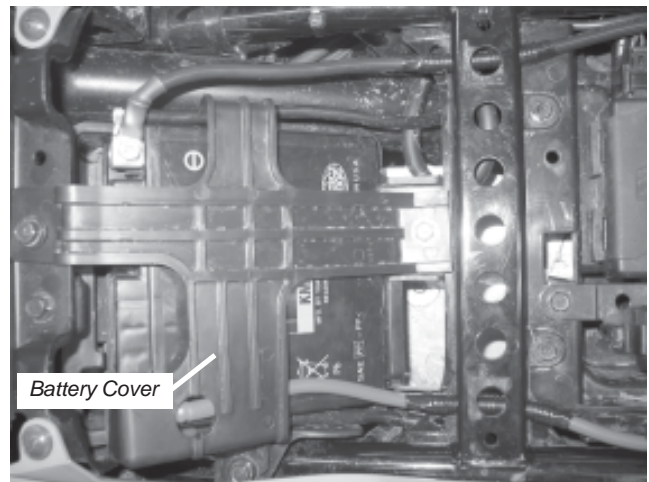

Figure 13

- j. Use cable ties, supplied in the winch kit, to secure all electrical cables to the ATV frame, as needed. Avoid all moving and potentially hot components of the ATV when routing the electrical cables. Avoid areas where the wiring could be pinched when components are reinstalled (such as the seat).
- k. Attach the red wire to the positive red contactor post and battery positive terminal. Attach the black wire to the black contactor post and battery negative terminal. Reposition the protective boot over the positive battery terminal.

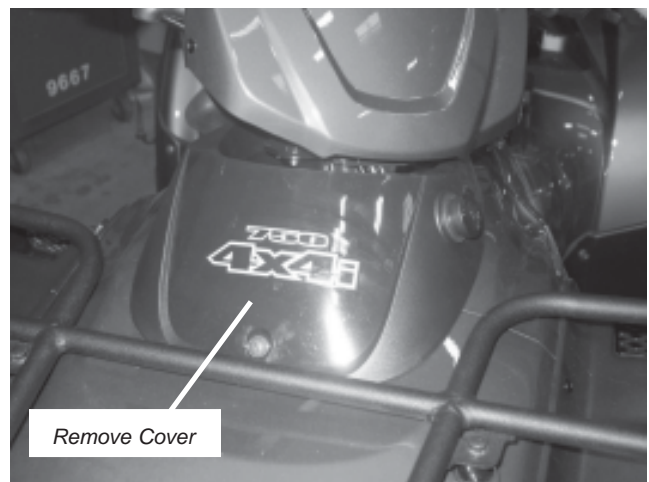

Figure 14

- l. Re-assemble all panels and covers.

- m. Reinstall the battery cover and securely tighten fasteners.
  
- n. Refer to the winch installation and specification guide for full and complete details on wiring installation.

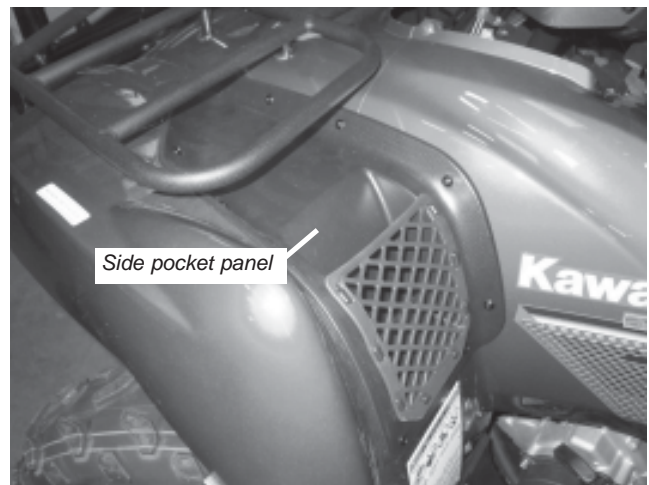

Figure 15

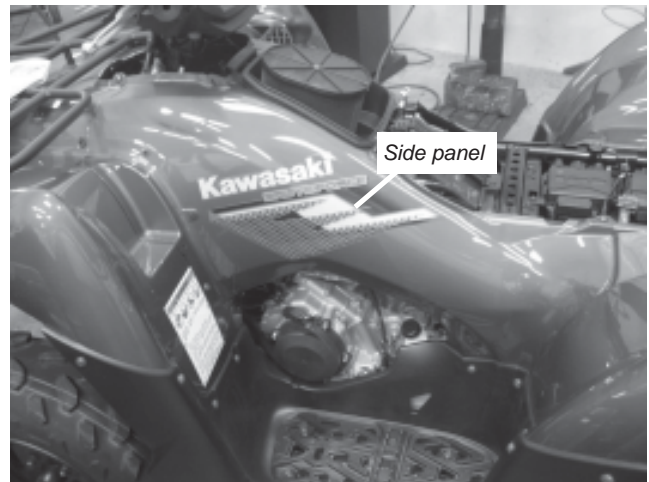

Figure 16

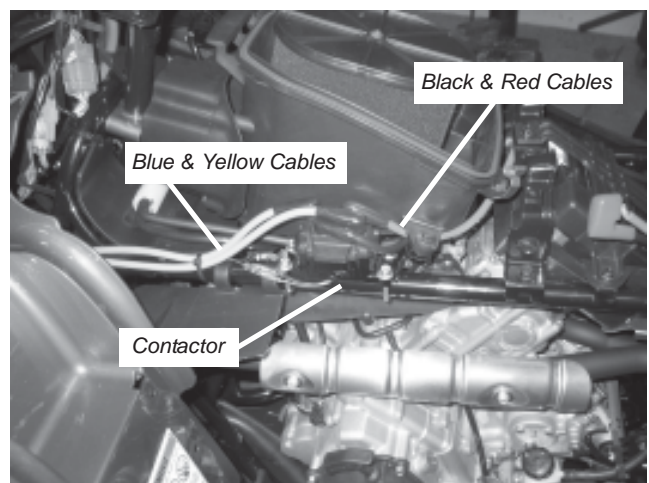

Figure 17



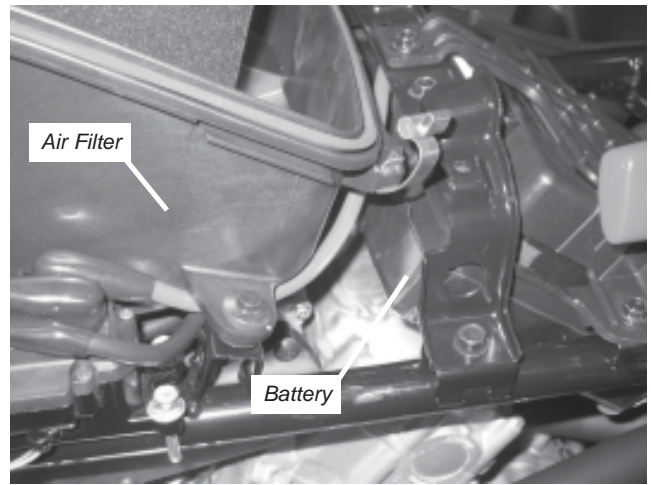

Figure 18

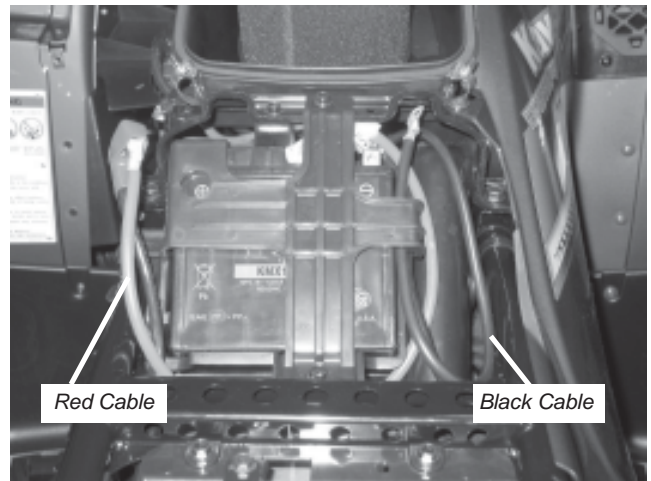

Figure 19

** WARNING**

**READ THE VEHICLE'S OPERATOR MANUAL, WINCH OPERATOR MANUAL, AND ALL WARNING LABELS PRIOR TO OPERATION OF ATV AND WINCH.**

**WARNING**

**AVOID ALL MOVING AND POTENTIALLY HOT COMPONENTS OF ATV WHEN ROUTING ELECTRICAL CABLES. AVOID AREAS WHERE THE WIRING COULD BE PINCHED WHEN COMPONENTS ARE REINSTALLED. FAILURE TO DO SO CAN RESULT IN PRODUCT FAILURE WHICH CAN LEAD TO VEHICLE DAMAGE AND OPERATOR INJURY OR DEATH.**

**V. MAINTENANCE/CARE**

1. Inspect all parts on the winch, winch mount, and related hardware prior to each use. Replace all hardware that appears rusted or deformed.
2. Inspect all nuts and bolts on the winch, winch mount, and related hardware prior to each use. Tighten all nuts that appear to be loose. Stripped, fractured, or bent bolts or nuts need to be replaced.
3. Check all cables prior to use. Replace cables that look worn or frayed.
4. Check all moving or rotating parts. Remove debris that may inhibit the part from moving freely.

** WARNING**

**PERFORM REGULAR INSPECTIONS ON THE WINCH, WINCH MOUNT, AND RELATED HARDWARE. NEVER OPERATE THE WINCH WITH DAMAGED OR MISSING PARTS. FAILURE TO FOLLOW THIS WARNING MAY CAUSE VEHICLE DAMAGE AND OPERATOR INJURY OR DEATH.**