



**INSTALLATION INSTRUCTIONS / OWNER'S MANUAL:  
AUDIO MINI  
OFF-ROAD SOUND SYSTEM FOR POLARIS RANGER/RANGER CREW  
MODELS**

*www.hoppeindustries.com*  
22667 FM 15 Troup, TX 75789  
(262) 552-2770

Thank you for choosing the Hoppe *Audio Mini* off-road sound system. We hope you enjoy the off-road sound system, and we ask that you follow these instructions very closely. Doing so will save you time and ensure that your experience with the new *Audio Mini* is a positive one.

**We strongly suggest that you read the complete instructions before beginning the installation process to eliminate the possibility of performing unnecessary work.**

Having a safe and clean environment and using the proper tools is essential for a successful installation.

**It is critical that proper eye wear, ear protection, and protective clothing is worn throughout the top installation.**

When you receive your *Audio Mini* off-road sound system, please check to ensure that all parts and hardware are included. If there are any parts missing or if you have any questions concerning the system at this time call Hoppe at (262)-552-2770 Mon-Thur. 8am-5pm CST or Friday 8am -12pm CST. Or you can email us at [tech@hoppeindustries.com](mailto:tech@hoppeindustries.com).

Hoppe reserves the right to change specifications, equipment, or designs at any time without notice and without incurring obligation.

# **TABLE OF CONTENTS**

|   |   |
|---|---|
| SECTION 1 – <i>Tools Required</i> .....                     | 4 |
| SECTION 2 – <i>About your Audio Mini sound system</i> ..... | 4 |
| 2.1 Applicable Year Models: .....                           | 4 |
| 2.2 Audio Equipment Details:.....                           | 4 |
| 2.3 Warranty: .....   | 5 |
| 2.4 Care and Maintenance: .....                             | 5 |
| 2.5 Warnings:.....  | 6 |
| SECTION 3 – <i>Pre-Installation Inspection</i> .....        | 7 |
| SECTION 4 – <i>Installation</i> .....                       | 8 |



## **SECTION 1 – Tools Required**

- Socket wrench set
- Combination wrench set
- Wire cutters
- Wire stripper and crimping tool (2016-down models)

In addition to the above items, you may need shop supplies such as electrical tape, wire ties, thread locking compound, etc.


## **SECTION 2 – About your Audio Mini sound system**

### **2.1 Applicable Year Models:**

This *Audio Mini* off-road sound system is designed to fit the following Ranger/Ranger Crew models:

- 2017-2020 RANGER 1000 & RANGER 900 (all versions)
- 2017-2018 RANGER DIESEL (STD, HST)
- 2017-2020 RANGER CREW 1000, RANGER CREW 900, & RANGER CREW DIESEL (all versions)  
All versions means it includes sub models such as XP, North Star, Premium, EPS, Texas, and High Lifter editions.
- This system is compatible with most front windshields (Poly, Glass, and Tip-Out) and roofs (roof liners would require modification, or removal of the front liner, to be compatible).
- This system is not compatible with rear view mirrors that mount to the visor or visor bracket.
- This system is not compatible with wiper kits that mount high up by the visor.

### **2.2 Audio Equipment Details:**

Your *Audio Mini* off-road sound system is powered by  using their marine series audio equipment. This equipment is designed to function in all weather conditions with an IPX6 water resistance (powerful water jet) rating. The stereo is specifically engineered to provide excellent sound quality and volume in an open air environment so you can enjoy your music on the go.

To learn more details about your stereo system, you can access product information and manuals for the stereo equipment here:

- KMC2 receiver: <https://www.kicker.com/kmc2>
- Speakers: <https://www.kicker.com/41KM604W>

You can feel free to crank up the volume without much worry of harming your system. However, it is wise to use a little common sense. If you hear any distortion, back off a little.

Use the equalizer settings in your KMC2 receiver to adjust the settings to your preferences.

### **2.3 Warranty:**

Your *Audio Mini* comes equipped with a 1 year limited warranty covering the light, the stereo equipment, and the fiberglass enclosure. The date of warranty coverage will be determined by the registration date of the warranty card or online warranty registration.

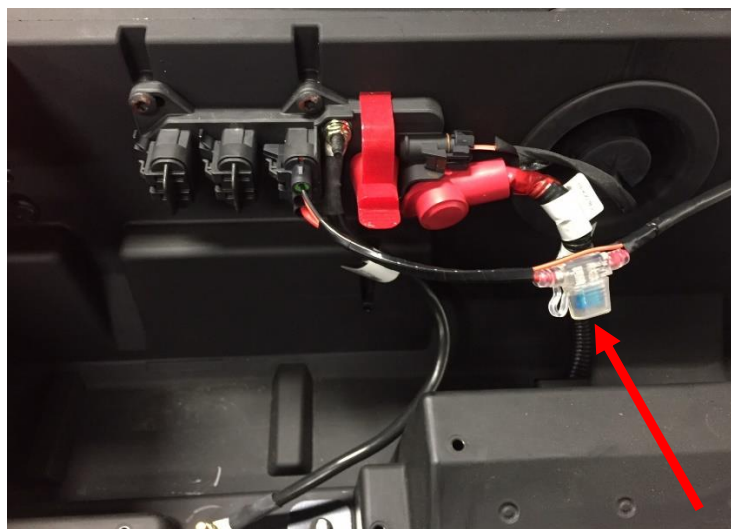
<http://www.motortrike.com/TrikeAccWarranty.aspx>

If the warranty is not registered with Hoppe, the warranty period will begin when the Audio Mini was shipped from Hoppe's factory.

### **2.4 Care and Maintenance:**

Your off-road sound system does not require any maintenance other than an occasional cleaning. To clean your audio system, simply hose off or power wash from a distance. If needed, use a mild automotive soap and sponge or brush. Use common sense. Do not use a high pressure power washer up close where it could cut, scar, or force water beyond the design intent of the enclosure, light, or stereo equipment.

There is an inline fuse, close to the end of the chassis harness where it connects to the factory terminal block. It can be accessed by pulling the cap off of the fuse holder. See Figure 1.



**Figure 1: Fuse location.**

- Fuse 1: 15 amp mini fuse for light / radio receiver power.

There is also a 40 amp capacity skirted mini ignition relay built into the chassis harness next to the inline fuse. See Figure 2.



**Figure 2: Chassis harness ignition relay**

## ***2.5 Warnings:***

This off-road system adds up to 25 lbs. to your vehicle and is located up high on the roll cage. This increases the vehicle's center of gravity and changes the vehicle dynamics and handling characteristics. Use extra caution as you learn the driving characteristics of your vehicle with your new off-road sound system installed. High speed cornering, off camber or side hill, acceleration, and braking performance will be negatively impacted by the weight of the sound system.

Do not listen to your stereo at an uncomfortable volume for extended periods of time. Potential hearing loss may result.

## **SECTION 3 – Pre-Installation Inspection**

Included in your off-road sound system are the following components:

- Pre-assembled *Audio Mini* off-road sound system (All speakers and electronics come preinstalled with interior wire harness.)
- Chassis wire harness
- Mounting brackets
- Hardware bag
- Zip ties and cable mounts
- Alcohol wipe

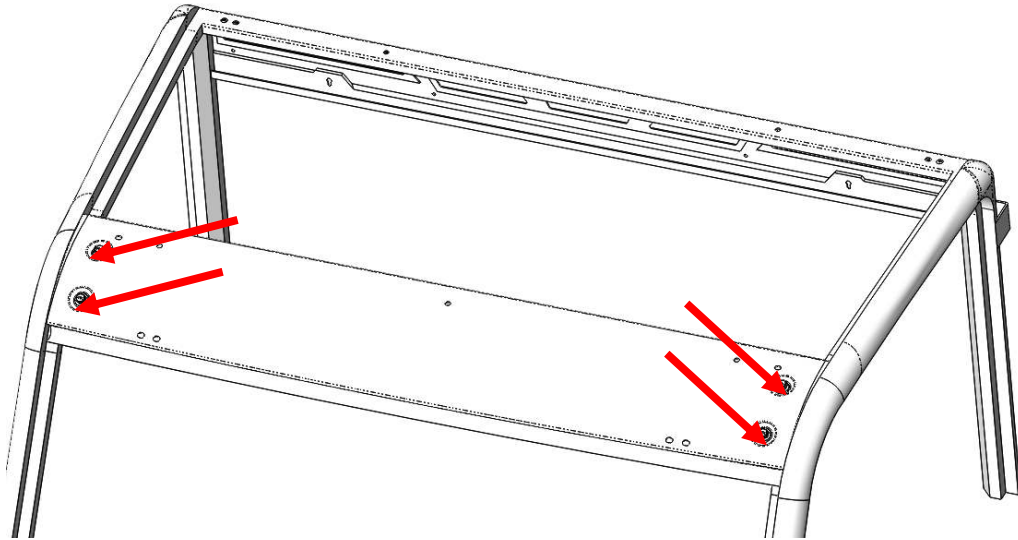
If any of the parts are missing, damaged, or you have any questions concerning them, please call Hoppe at (262)-552-2770 Mon-Thur. 8am-5pm CST.

In addition to accounting for all of the parts that you should receive with the top, you should inspect the vehicle in the following ways.

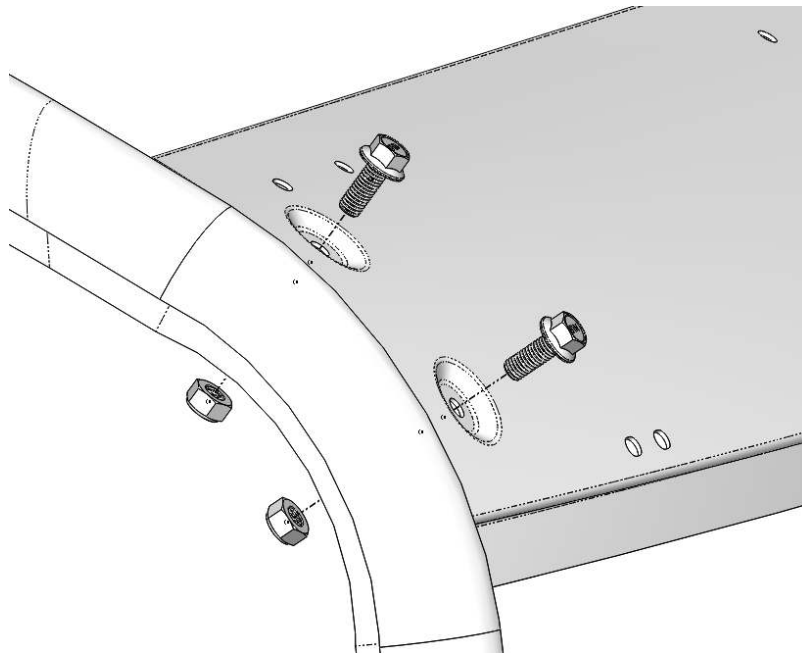
- Ensure that the vehicle is equipped with the factory roll cage, and the roll cage has not been bent out of shape in a roll over.
- Make sure the vehicle does not have any aftermarket accessories that are incompatible with the top. **Note: This system fits inside the factory windshield visor and is compatible with most windshields that interface with this visor.**
  - **This system is not compatible with rear view mirrors that mount to the visor bracket or visor slot openings.**
  - **This system is not compatible with windshield wiper kits that mount high up by the visor.**
- Make sure the battery is in good condition and holds a charge.
- Make sure the charging system is in good condition.

## **SECTION 4 – Installation**

1. Remove the factory bolts and nuts from the visor. Save the hardware for installation. **Note: If you have a roof installed, you will need to remove the roof or loosen the front mounting bolts to gain access to the visor bolts.** See Figure 3 and Figure 4.



**Figure 3: Remove the factory visor hardware.**



**Figure 4: Close up of visor hardware.**

2. Align the brackets between the visor and the welded frame mount. Replace the bolts, and loosely tighten the nuts to allow for adjustment of the *Audio Mini* placement. Verify correct orientation of the mounting brackets. See Figure 5. **Note: Reinstall your roof after this step, as you will not be able to access any bolts in the visor once your *Audio Mini* is installed.**



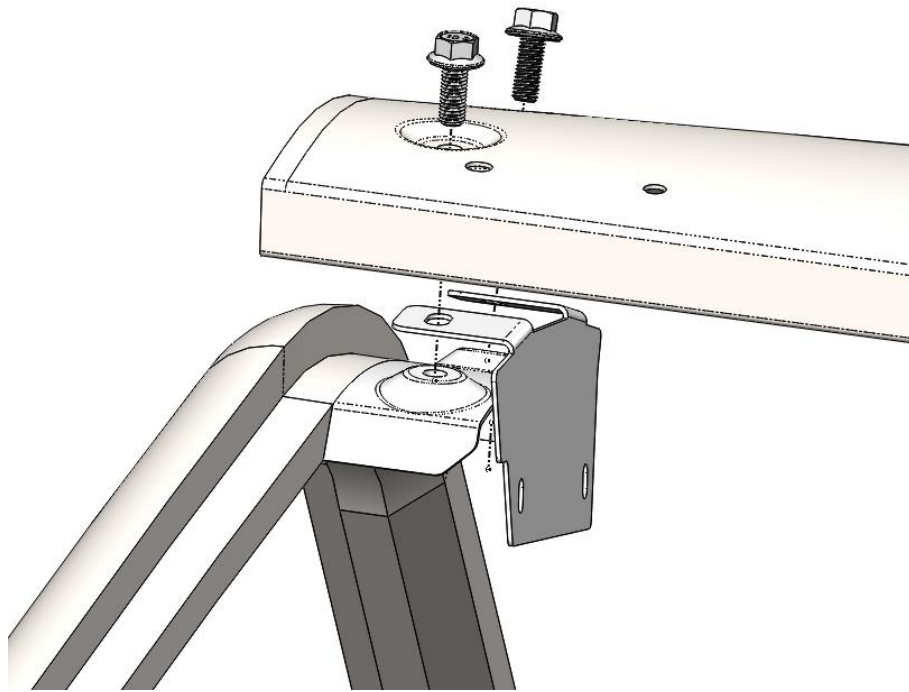


Figure 5: Mounting locations of *Audio Mini* brackets.

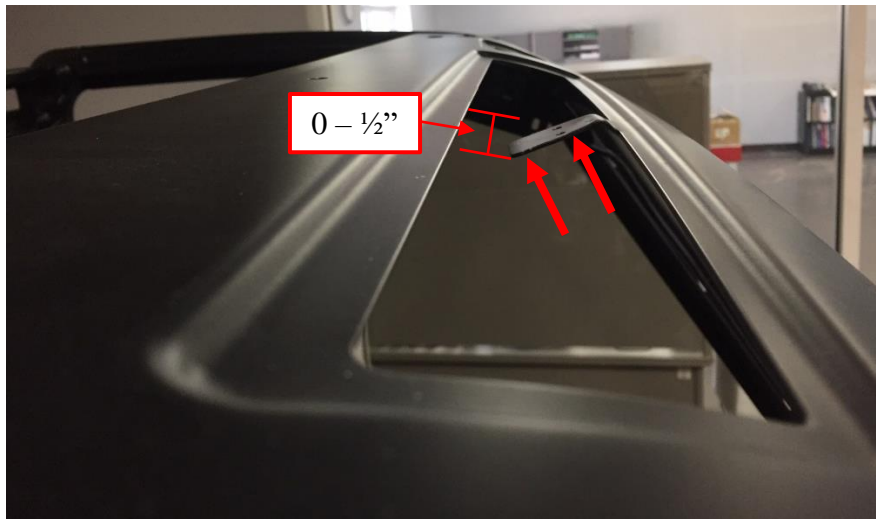
3. Run the connector from the chassis harness behind the *Audio Mini* mounting bracket before mounting the unit to the brackets. See Figure 6.

**Note: The connector will not fit between the visor and the *Audio Mini* once it is mounted to the brackets, so this step is important to not repeat work.**



Figure 6: Placement of the chassis harness connector before mounting the unit.

4. Bend the rear-view mirror bracket upwards with a pair of pliers or vice-grips, so that it does not interfere with the lid of the *Audio Mini*. The bottom of the bracket should be 0 - 1/2" below the lip of the visor. See Figure 7.



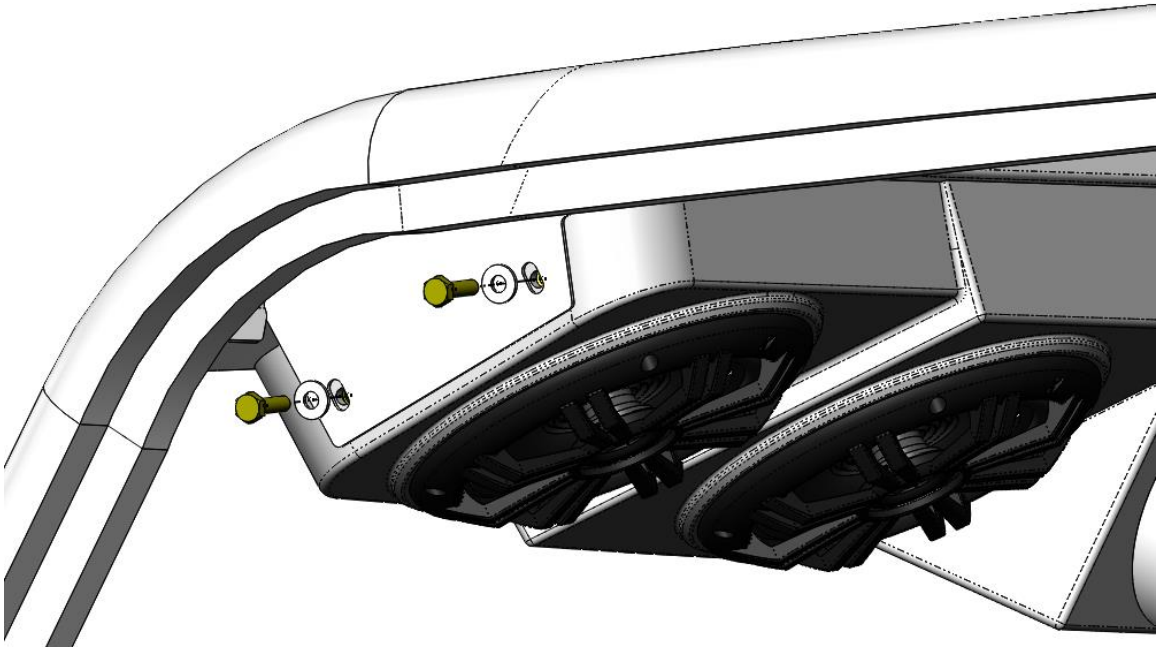
**Figure 7: Mirror bracket bent out of the way.**

5. Connect the chassis harness and the sound system harness by lifting the unit towards the visor. See Figure 8.

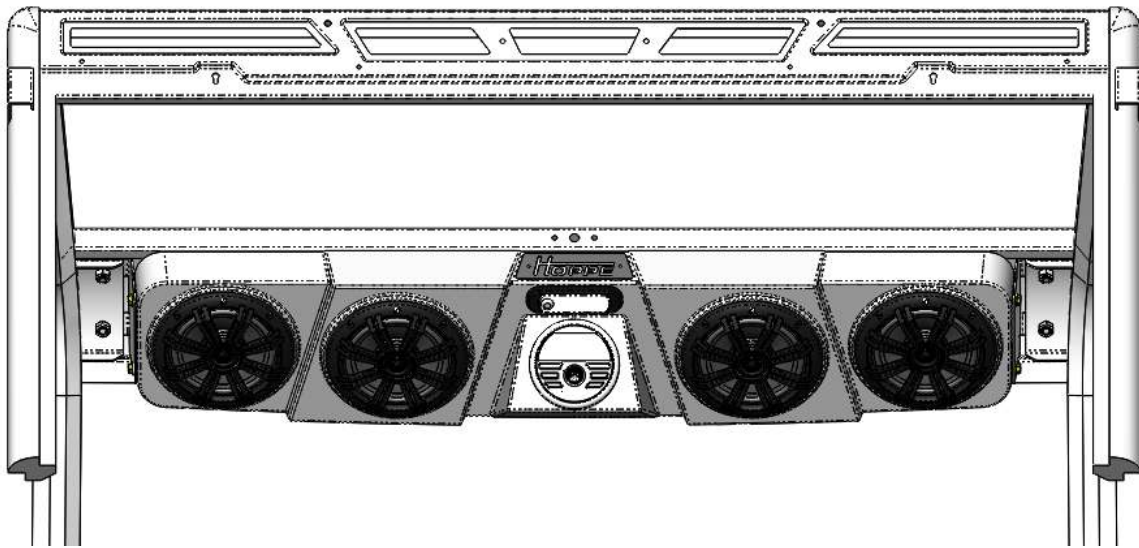


**Figure 8: Connect the chassis harness to the sound system.**

6. Using an assistant, hang the *Audio Mini* off-road sound system on the brackets using the supplied  $\frac{1}{4}$ "-20 bolts and washers (loosely tightened). **Note: The sound system weighs up to 25 lbs. Since you will have to lift and bolt each end, it is helpful to have an assistant for this step.** See Figure 9 and Figure 10.



**Figure 9: Install the 1/4"-20 bolts and washers to mount the Audio Mini to the brackets.**



**Figure 10: Loosely install the sound system on the mounting brackets.**

7. Tighten the 4 visor bolts so that the *Audio Mini* is centered between the front and rear edge of the visor. See Figure 11.

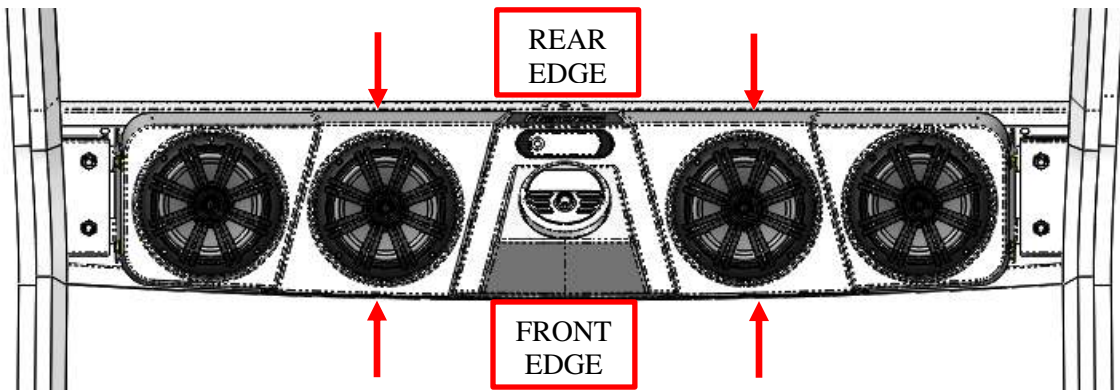


Figure 11: Audio Mini centered between visor edges.

8. Tighten the 4 mounting bracket bolts after achieving the desired up-down position relative to the visor. Slots in the brackets allow up-down movement. See Figure 12.

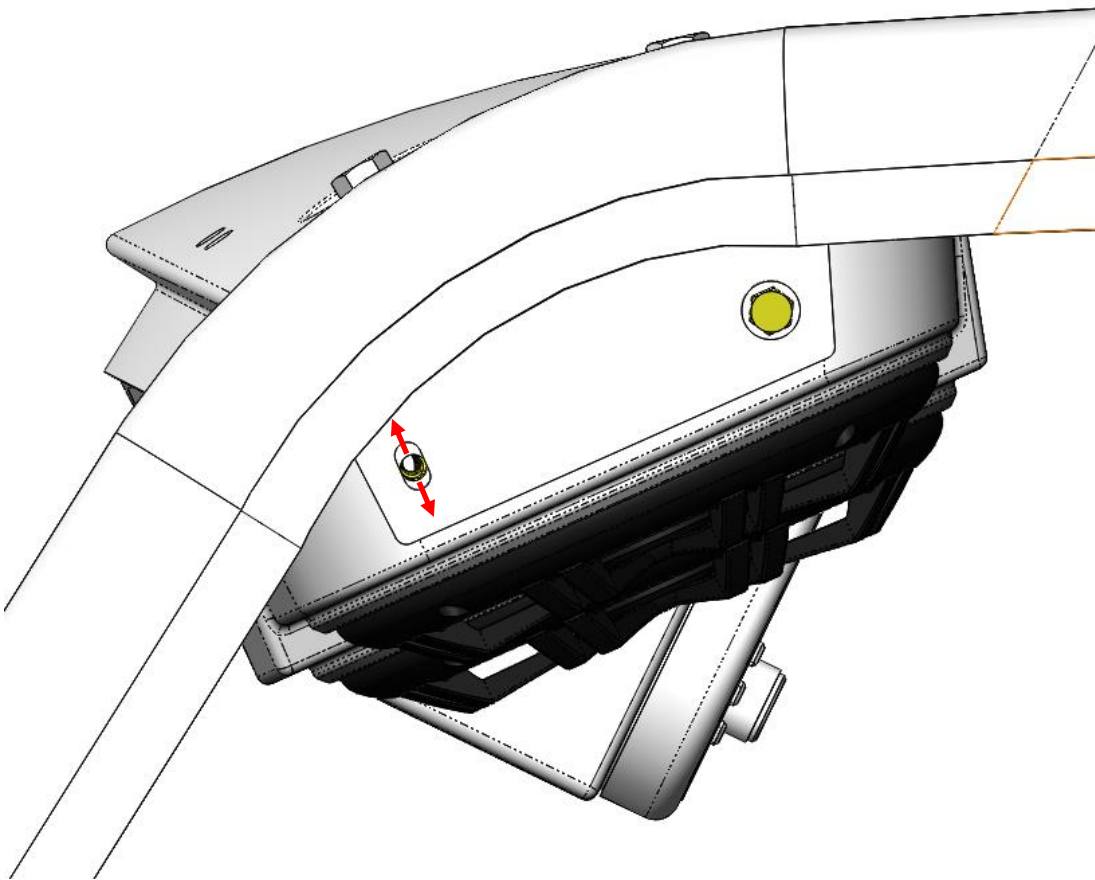


Figure 12: Up-down positioning of the Audio Mini.

9. Route the chassis harness, using the provided zip ties and cable mounts, down the driver's front pillar. Zip ties and mounts are at the indicated locations. Using the provided alcohol wipe, clean the cage surface thoroughly before applying the cable mounts. **Note: If you have a windshield or plan to add one, we recommend applying the cable mounts to the inside surface of the A-pillar.**

If you do not have a windshield, apply the cable mounts in the windshield recess of the A-pillar as shown. See Figure 13.



Figure 13: Route the chassis harness down the driver's front pillar.

10. Remove the radiator hood access panel from the front of the vehicle by rotating the ¼ turn clips, lifting, and sliding towards the front of the vehicle. See Figure 14.



Figure 14: Remove the radiator hood access panel.

11. Remove the right Torx screw to route the wiring under the plastic panel. See Figure 15.

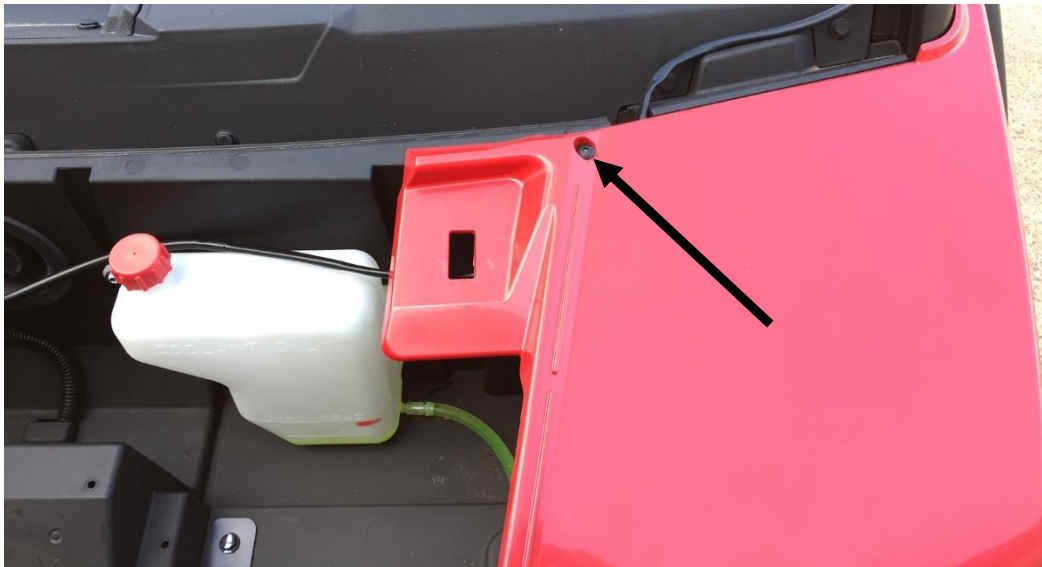
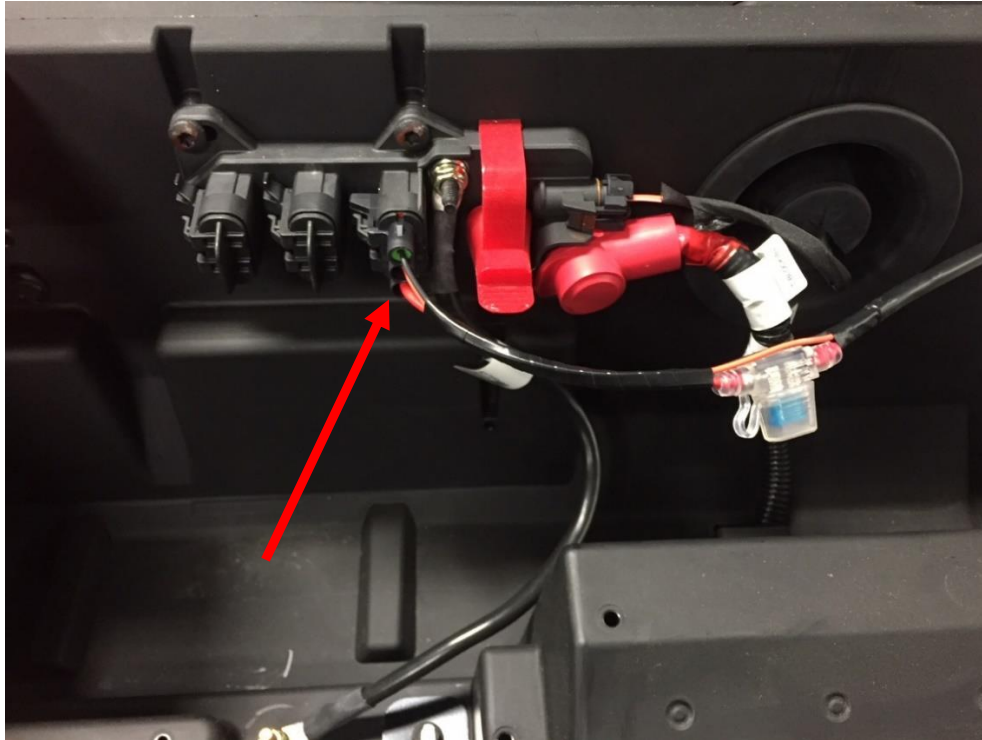


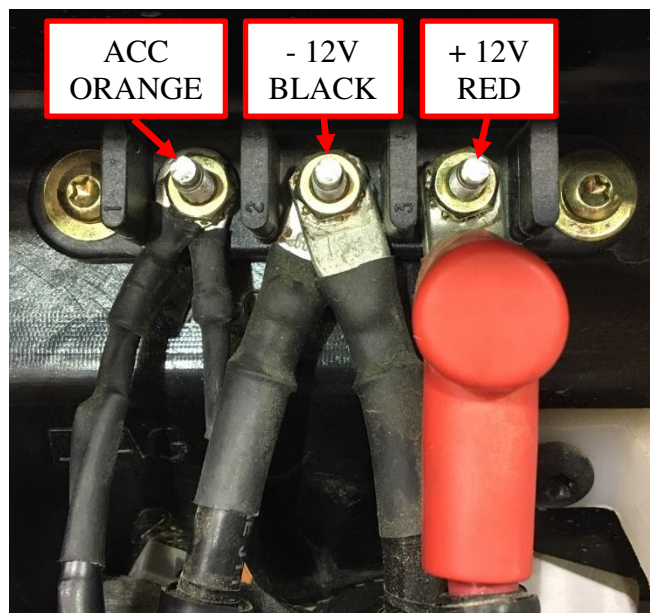
Figure 15: Remove the Torx screw to run the chassis harness under the panel.

12. Plug the chassis harness into the factory accessory port. **Note: All accessory ports will power the unit, if you are already using any ports for other accessories.** See Figure 16.

**If you have a model without the factory busbar, you will need to cut the harness connector off, strip the wires back, and crimp on the included ring terminals.** Remove the locknut from each post as you connect the cables, and replace the locknuts to clamp the cables on top of the existing cables. Connect the red harness wire to the terminal post with the existing red battery cable (+ 12V). Connect the orange harness wire to the terminal post with the existing orange wire (12V ACC). Connect the black harness wire to the terminal post with the existing black battery cable (- 12V). See Figure 17.



**Figure 16: Accessory port connection.**



**Figure 17: Terminal post connection for models with 3-post terminal block.**


13. Reinstall the hood and Torx screw.

14. You are now ready to enjoy the music and lighting provided by your *Audio Mini* off-road sound system. Basic operation works as follows:

- Turn the vehicle ignition switch on to power up the stereo system. (You must press the power button for first time connections or if the power was previously turned off manually.)
- Press the mode button on the stereo receiver to select the input source from AM/FM radio or Bluetooth.
- Hold the mode button to access additional menus.
- The dome light can be used with or without the vehicle's ignition switch on. Press the on/off switch to activate the light. **Warning: Extended use of the dome light without the vehicle's charging system functioning will deplete the battery and the engine may not start.**

To learn about the more advanced features and operation of your stereo, visit the Kicker website links found in SECTION 2 – About your Audio Mini sound system of this document.

Thank you for choosing Hoppe *Audio Mini* off-road sound system for you Polaris Ranger UTV. We hope you enjoy your new sound system and lighting. We invite you, in your travels, to stop by our manufacturing plant in Troup, Texas, for a factory tour and to meet the people who designed and manufactured your *Audio Mini* off-road sound system. This

will also give you an opportunity to check out our sister company  and our extensive line of trike conversions, motorcycle, and power sports accessories.

We believe you will be impressed by what you witness and the people you will meet.