

Install the Ring Gear Shim onto the Ring Gear.

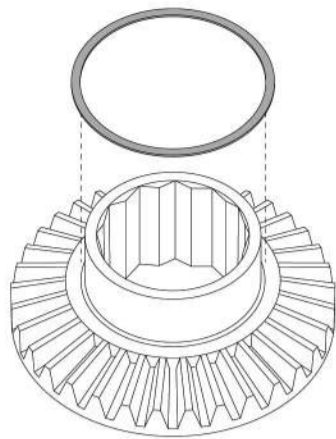

21

Install the SANDCRAFT™ Solid Tapered Dowell Pin into the Ring Gear. Install the Ring Gear into the Differential Case.

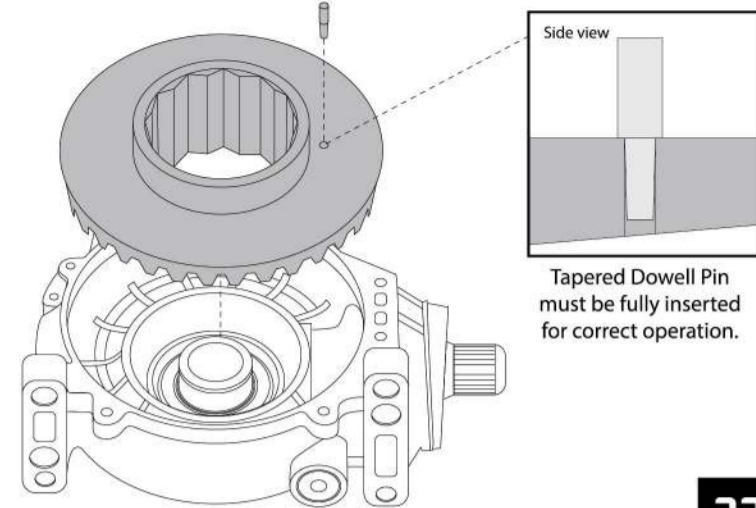

22

Install the Torsion Spring. Torsion Spring hook ends stack left over right

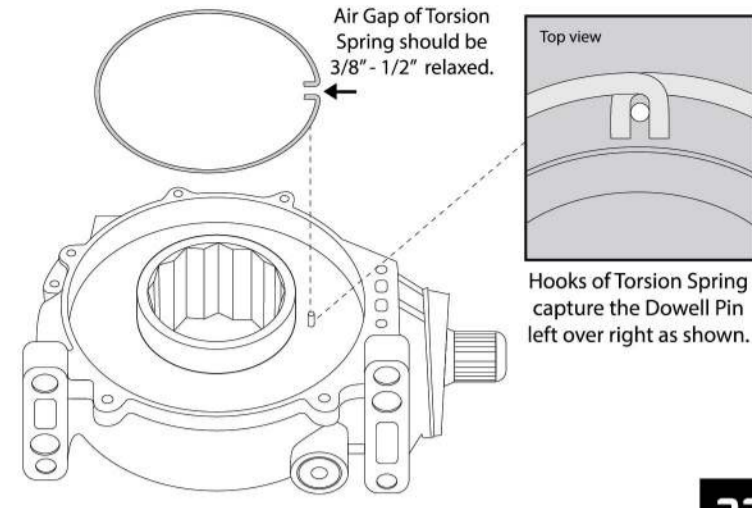

23

Install H Clips and Rollers into SANDCRAFT™ Sprague Cage. Use Rubber Bands to temporarily hold the Rollers in place until installation.

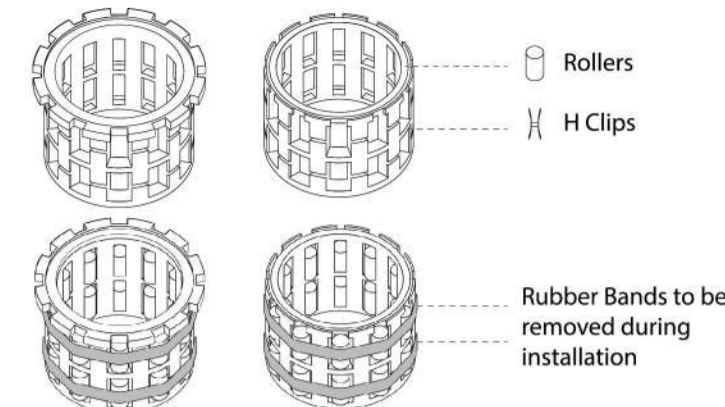

BOMBPROOF BULLETPROOF

24

Install the Sprague Cage Assembly into the Differential. Remove the Rubber Bands as the Sprague Cage Assembly is inserted.

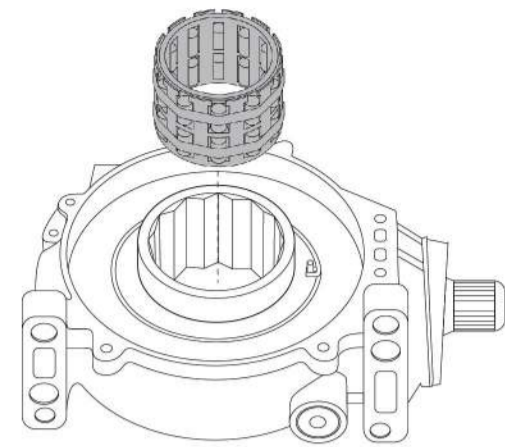

\*BOMBPROOF KITS FOLLOW ASSEMBLY STEPS 25B-26B BELOW

25A

Install the SANDCRAFT™ Spring Retainer and Armature Plate (teeth down)

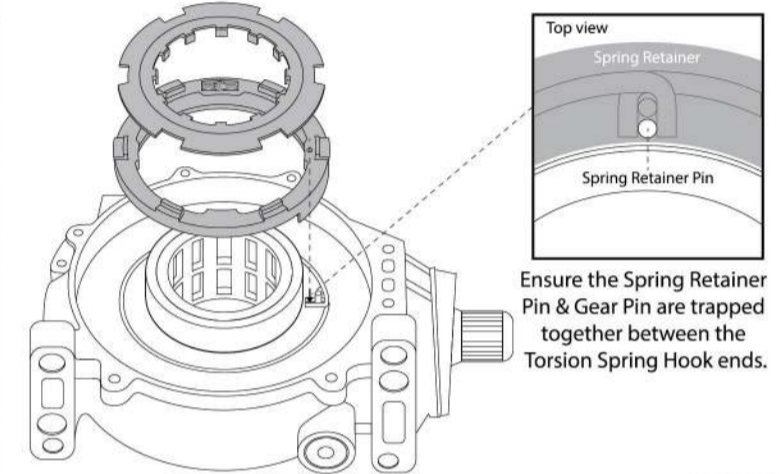

\*BOMBPROOF KITS FOLLOW ASSEMBLY STEPS 25B-26B BELOW

26A

Install the Driver Side Axle Hub and Bearing Into the Differential Case.

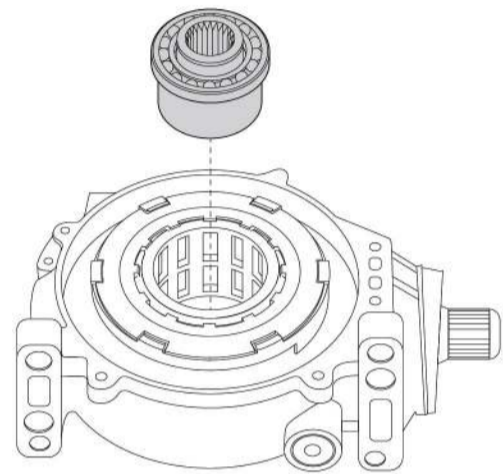

27

Install the SANDCRAFT™ Driver Side Axle Seal into the Differential Cover. Install the Cover Seal and Cover Cushion into the Differential Cover.

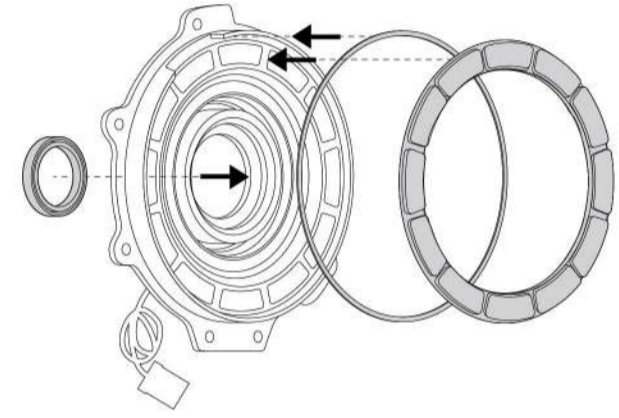

28

Install the differential cover using the stock hardware. Torque to 8 ft-lb.

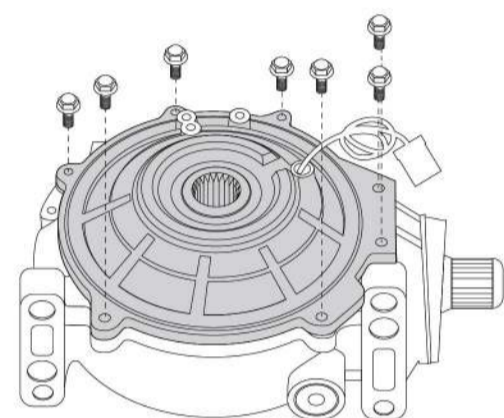

29

Install the Sandcraft RCR Pinion Seal. Remove the Zip Tie from Differential Cover Wire and fill Differential with oil before use.

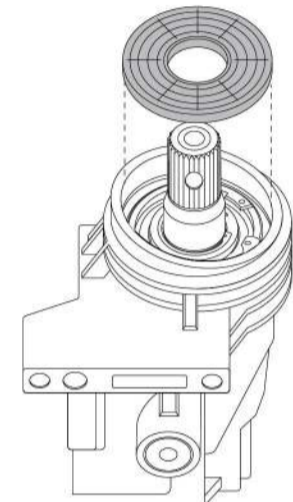

30

**BULLETPROOF**  
2014 POLARIS 1000

Grey Plastic Ring

Driver Side Hub Passenger Side Hub

16B

**BULLETPROOF**  
2015 POLARIS 1000

Grey Plastic Ring Black Plastic Ring

Driver Side Hub Passenger Side Hub

16C

**BULLETPROOF**  
2016 POLARIS TURBO & SOME 2016 POLARIS 1000

Grey Plastic Ring

Driver Side Hub Passenger Side Hub

16D

**BULLETPROOF**  
POLARIS 900 & 800

White Plastic Ring

Driver Side Hub Passenger Side Hub

16E



### BULLETPROOF & BOMBPROOF FRONT DIFFERENTIAL INSTALLATION INSTRUCTIONS

READ THIS ENTIRE INSTRUCTION MANUAL BEFORE STARTING

**ATTENTION! TO ENSURE CORRECT OPERATION, USE POLARIS DEMAND DRIVE FLUID.**

RUN MACHINE WITH FOUR-WHEEL DRIVE ENGAGED FOR 50-100 MILES, THIS WILL ALLOW YOUR DIFFERENTIAL TO PROPERLY MATE WITH THIS PRECISION-MADE ARMATURE PLATE.

SANDCRAFT™ will not be responsible for any damage resulting from mishandling, abuse, misuse, improper storage, improper installation, or improper operation, including use in conjunction with equipment that is mechanically incompatible with, or of inferior quality to, the product, as well as failure to maintain the environmental conditions specified by the manufacturer.

**BOMBPROOF**  
14-15 POLARIS 1000

Grey Plastic Ring

Bottom Spacers (Grey or Black) do not get reused on Passenger Side Hub Assembly

Driver Side Hub Passenger Side Hub

16F

**BOMBPROOF**  
16 POLARIS TURBO

Replace OE thick bearings with thin bearings & spacers

Driver Side Hub Passenger Side Hub

16G

**BOMBPROOF**  
17+ POLARIS TURBO & 1000

Remove white spacers - No spacers required for this application

Driver Side Hub Passenger Side Hub

16H

**BOMBPROOF**  
Install the SANDCRAFT™ Spring Retainer and Armature Plate (teeth up, smooth side down). The Armature Plate sets the Steel Sprague position.

Ensure the Spring Retainer Pin & Gear Pin are trapped together between the Torsion Spring Hook ends.

25B

**BOMBPROOF**  
Install the SANDCRAFT™ Sprague Cage Assembly into the Differential. Remove the Rubber Bands as the Sprague Cage Assembly is inserted.

26B

Secure the Differential Cover cable with a Zip Tie.

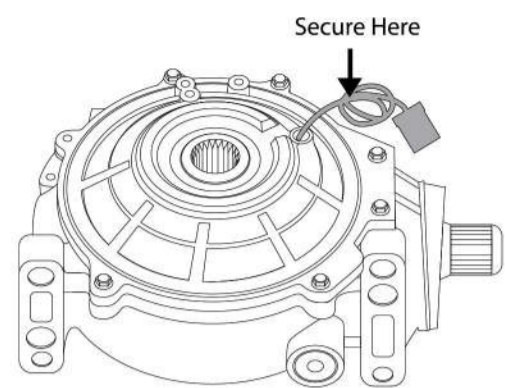

1

Remove the Bolts holding the Differential Cover in place and remove the Differential Cover. Retain hardware.

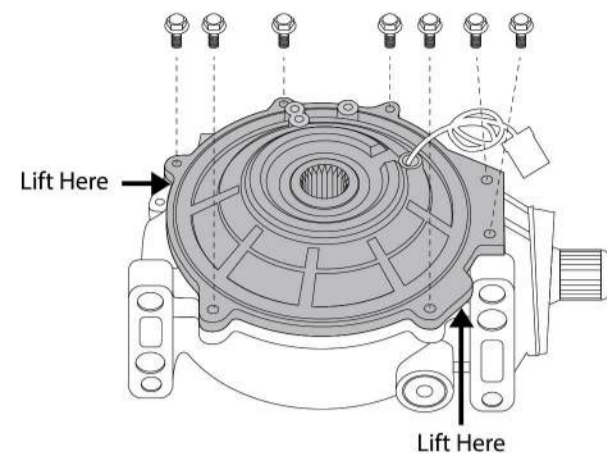

2

Remove the Cover Seal, Cover Cushion and Driver Side Axle Seal from the Differential Cover. Retain Cover Seal & Cover Cushion. Inspect and clean all surfaces.

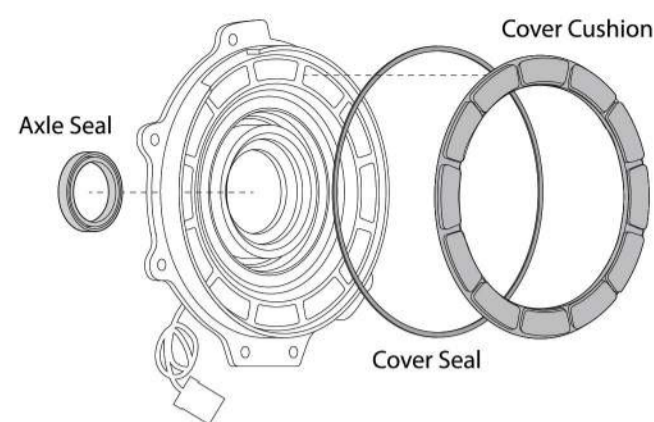

3

Remove the Driver Side Axle Hub and Bearing Assembly from the Differential Case.

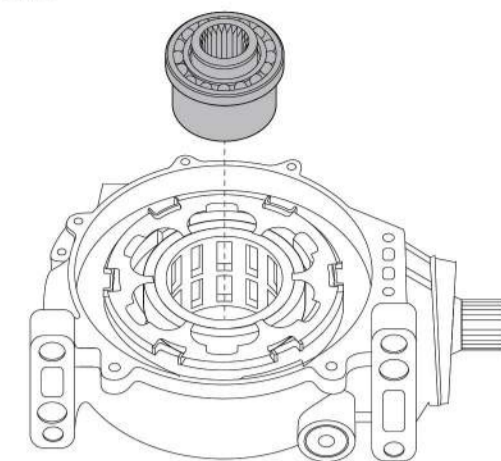

4

Remove the Armature Plate and plastic Spring Retainer.

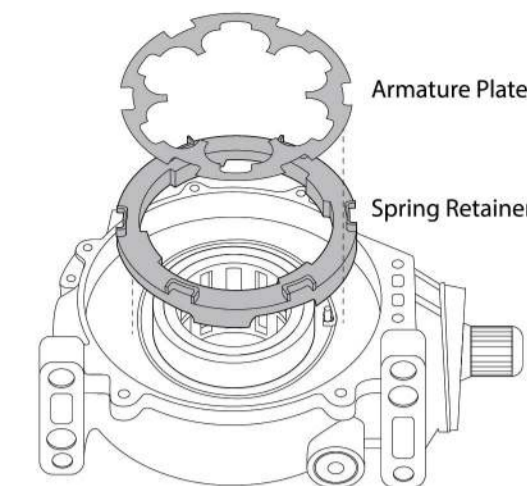

5

Remove the Torsion Spring.

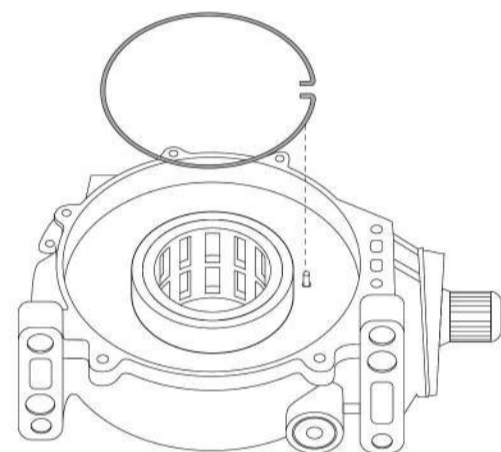

6

Remove the Sprague Cage. Be careful, the Rollers are under tension. Using rubber bands helps to retain the Rollers and H Clips.

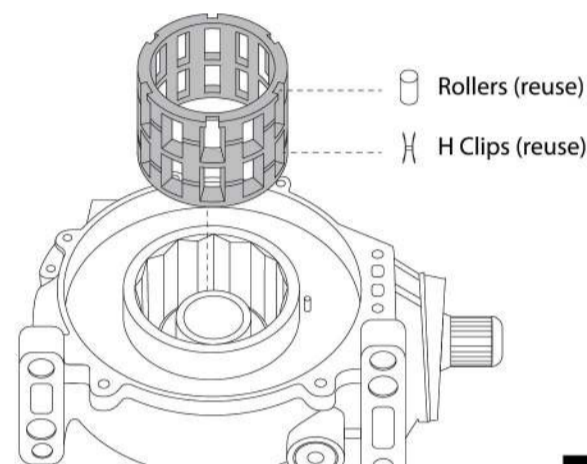

7

Remove Ring Gear from the Differential. Remove the Dowell Pin from the Ring Gear.

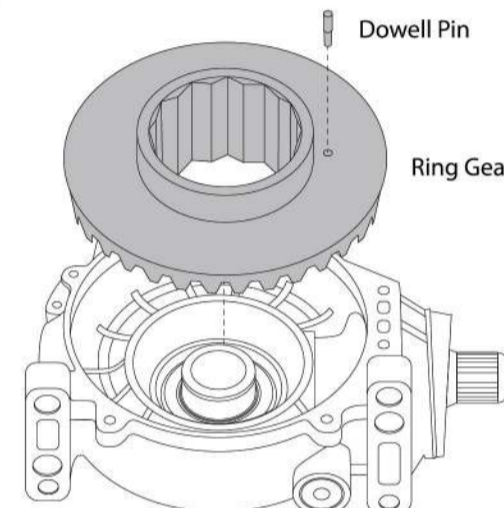

8

Remove the Ring Gear Shim from the Ring Gear. Retain Shim.

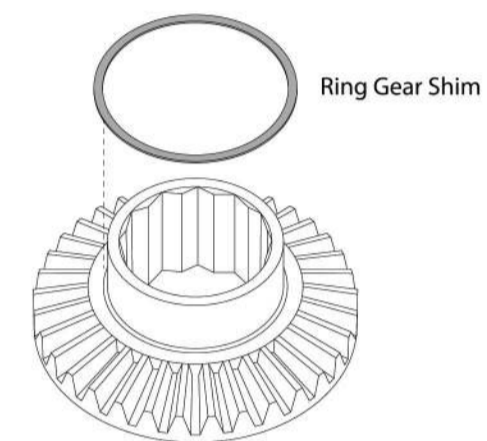

9

Remove the Passenger Side Axle Hub and Bearing from the Differential Case.

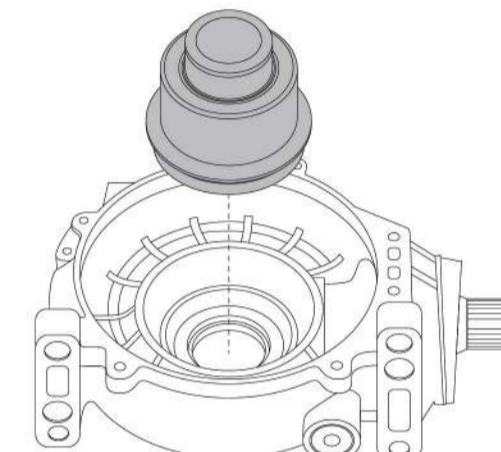

10

Remove the Axle Seal from the passenger side of the Differential Case.

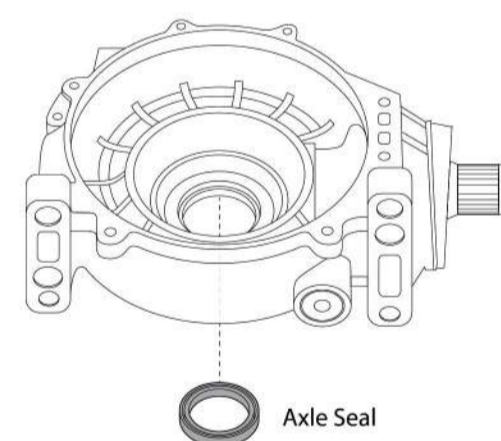

11

Remove the Pinion Seal.

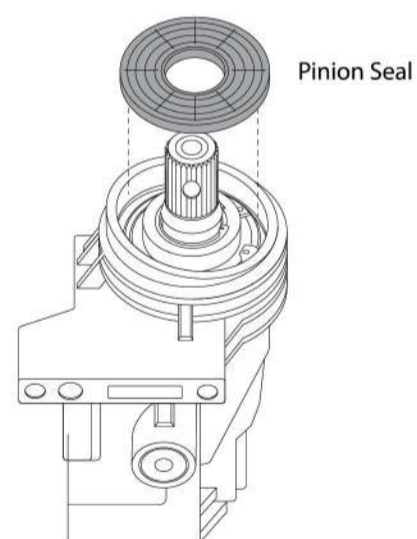

12

Remove the Large Tapered Snap Ring from the Bearing/Case. Remove the Small Snap Ring from the Pinion Gear/Bearing. Note the orientation of each Tapered Snap Ring. Retain hardware.

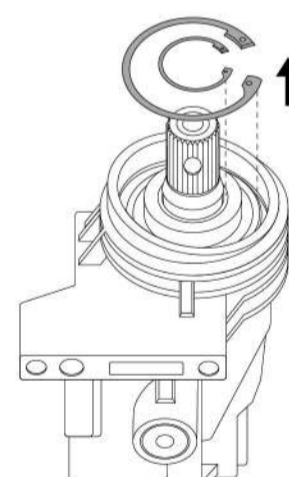

13

Remove the Pinion Gear/Bearing Assembly from the Differential Case.

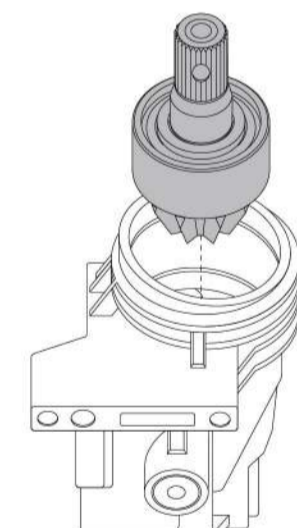

14

Remove the Pinion Gear Bearing. Remove the Axle Bearings. We recommend using a bearing press. Retain Plastic Ring from Male Axle Hub.

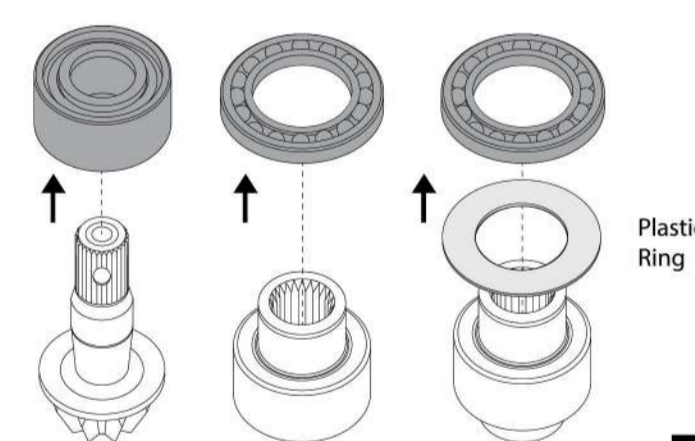

15

Re-install Plastic Ring on Male Hub. Install SANDCRAFT™ upgraded Pinion and Axle Bearings. We recommend using a bearing press.

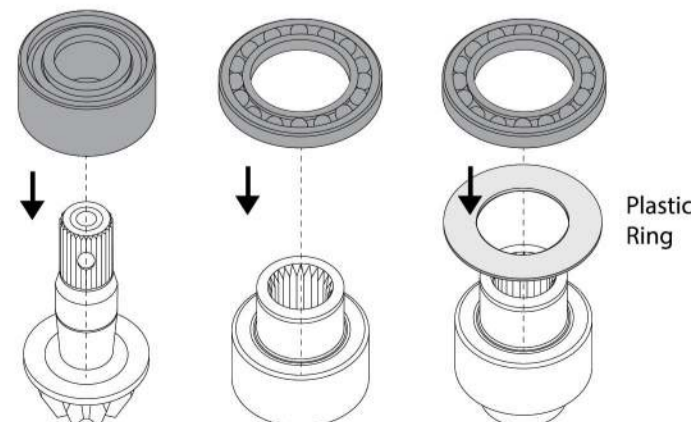

16A

17+ XP1000 & TURBO. SEE ADDITIONAL MODEL CONFIGURATIONS ON REVERSE SIDE

Install the Pinion Gear/Bearing Assembly into the Differential Case.

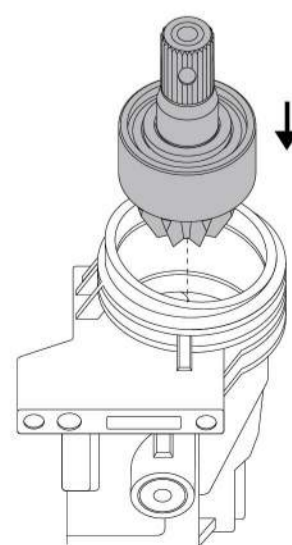

17

Install the large tapered snap ring into the bearing/case. Install the small snap ring into the pinion gear/bearing. Note the orientation, the tapered snap rings install with the flat side down.

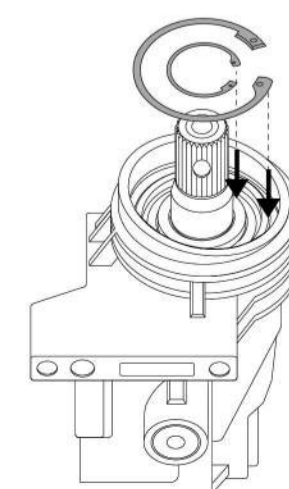

18

Install the SANDCRAFT™ Passenger Side Axle Seal into the Differential Case.

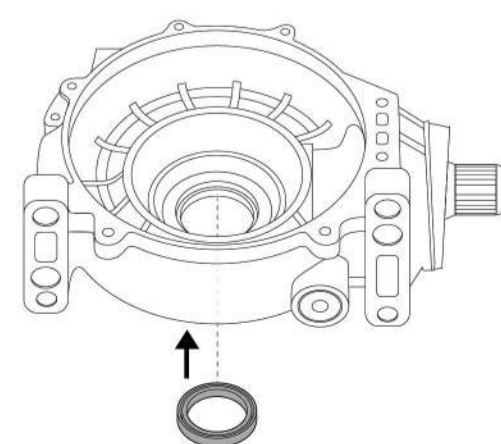

19

Install the Passenger Side Axle Hub and Bearing Assembly into the Differential Case.

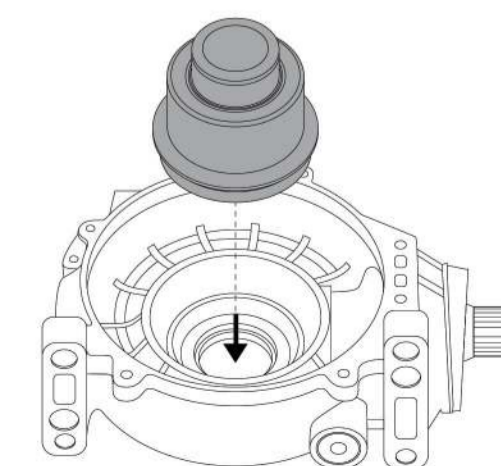

20