



(2014-2020) POLARIS RZR XP 1000 STAGE 5 FULL SYSTEM EXHAUST  
INSTALLATION INSTRUCTIONS

1. REMOVE PLASTIC COVER, AND ALL FACTORY HEAT SHIELDS.
2. REMOVE THE STOCK MUFFLER BY REMOVING THE 2 BOLTS ATTACHING THE MUFFLER TO HEADER PIPE.
3. DISCONNECT THE OXYGEN SENSOR BY FIRST DISCONNECTING THE CONNECTOR, THEN UNSCREWING FROM THE EXHAUST. **SEE IMAGE 1**
4. REMOVE THE STOCK SYSTEM STARTING AT THE EXHAUST MANIFOLD GOING TOWARD THE MUFFLER. BE SURE TO REMOVE THE TRIANGULAR SHAPED RUBBER HANGER. **SEE IMAGE 2**
5. REMOVE ANY REMAINING HEAT SHIELDS BENEATH THE STOCK MUFFLER.
6. LOOSELY PRE-ASSEMBLE THE MUFFLERS USING THE BILLET MOUNTING BRACKET. USING THE M8 ALLEN BOLTS, NYLOCK NUTS, FLAT WASHERS, BILLET SPACERS, SQUARE WASHERS, AND LONG BILLET BAR WITH THE TRINITY LOGO, BOLT THE MUFFLERS TO THE FRAME OF THE VEHICLE. **SEE IMAGE 3A & 3B**
7. ATTACH THE EXHAUST MANIFOLD FLANGE ONTO THE MOTOR AND SLIP ON THE REAR UPPER AND LOWER HEAD PIPES, USING THE SUPPLIED SPRINGS. **SEE IMAGE 4.**
8. SLIP ON THE TRINITY RACING X-PIPE USING THE SUPPLIED SPRINGS.
9. SLIDE ON TRINITY RACING UPPER AND LOWER HEAD PIPES TO THE FRONT OF THE X-PIPE AND ALIGN TO THE 4 BOLT EXHAUST FLANGES THAT ARE INSTALLED ON THE MUFFLER. USING THE SUPPLIED SPRINGS, ATTACH THE ENTIRE ASSEMBLY TOGETHER. **SEE IMAGE 5**
10. ATTACH ALL SPRINGS TO SECURE Y-PIPE AND HEAD PIPE.
11. TIGHTEN ALL HARDWARE TO OEM SPECS.
12. BEFORE STARTING VEHICLE, CLEAN ALL EXHAUST COMPONENTS TO REMOVE ANY FINGER PRINTS OR OIL RESIDUE.





IMAGE #1



IMAGE #2



IMAGE #3A



IMAGE #3B

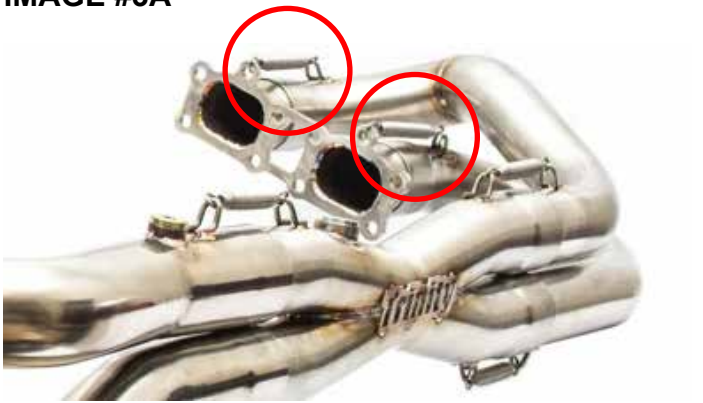
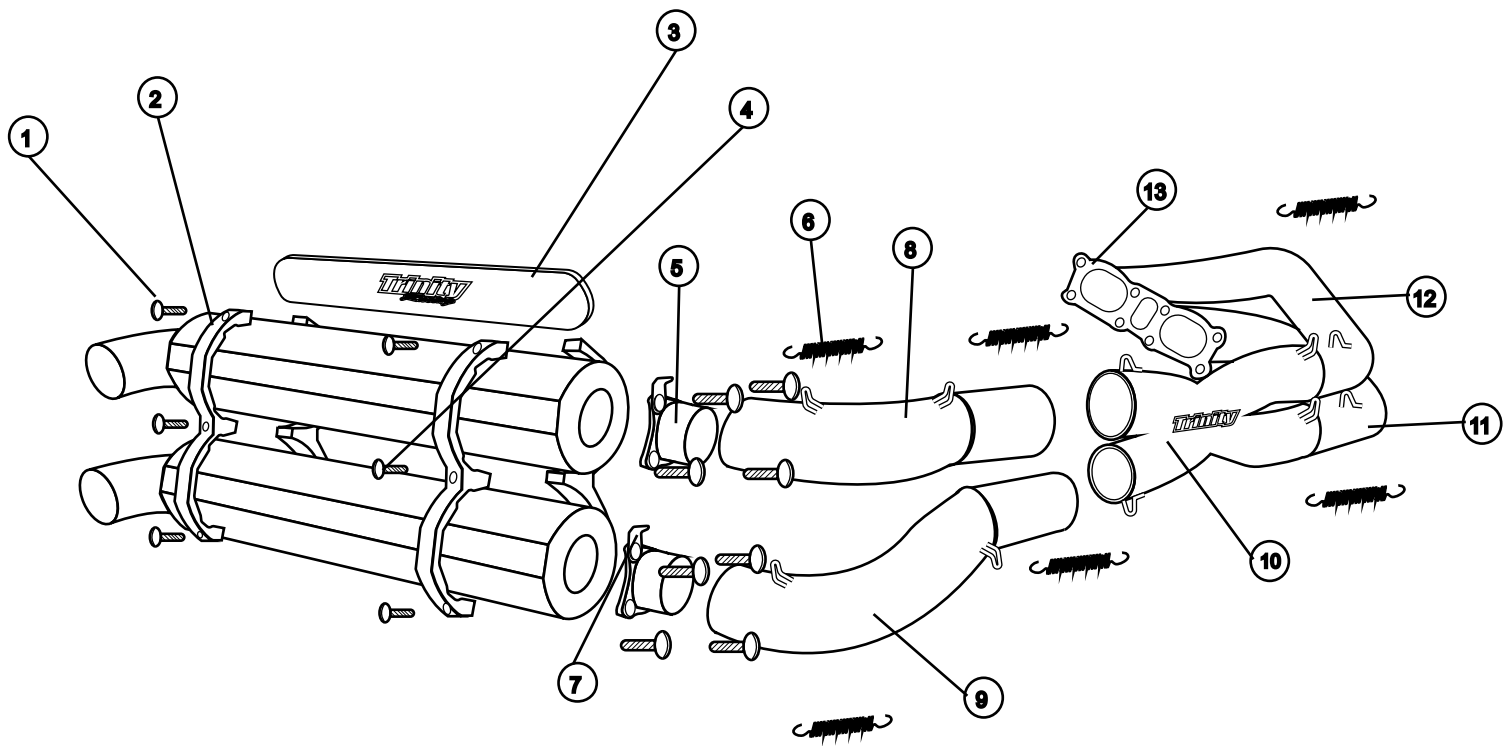

IMAGE #4



IMAGE #5



1	M8 X 25 SOCKET HEAD
2	BILLET 2-PIECE MOUNTING CLAMP
3	BILLET MOUNTING BRACKET
4	M8 X 70 SOCKET HEAD
5	4 BOLT MUFFLER FLANGE
6	RETENTION SPRING
7	RETENTION SPRING CLIP
8	UPPER HEADER PIPE
9	LOWER HEADER PIPE
10	X-PIPE
11	REAR LOWER PIPE
12	REAR UPPER PIPE
13	EXHAUST MANIFOLD FLANGE

#### **WARNING**

\* Trinity Racing exhaust systems will require adjustment to OEM fuel settings such as installation of an EFI programmer. Trinity Racing will not be held responsible for damages that occur during operation of your vehicle under improper fuel settings. Ultimately, it is the responsibility of the owner/rider to adjust fuel settings to specific riding conditions.

\* Inspection of the muffler packing is recommended following every 30 hours of runtime. Failure to maintain muffler packing will result in power loss, increased sound output, and damage to the muffler body or muffler components.

\* Trinity Racing exhausts systems are designed for high performance applications and are legal for closed course competition only. This product is not applicable nor intended for use on emissions controlled street, highway, or off-road vehicles.

5221 Oceanus Dr.  
 Huntington Beach, CA 92649  
 714.988.0339  
 www.trinityracing.com

