

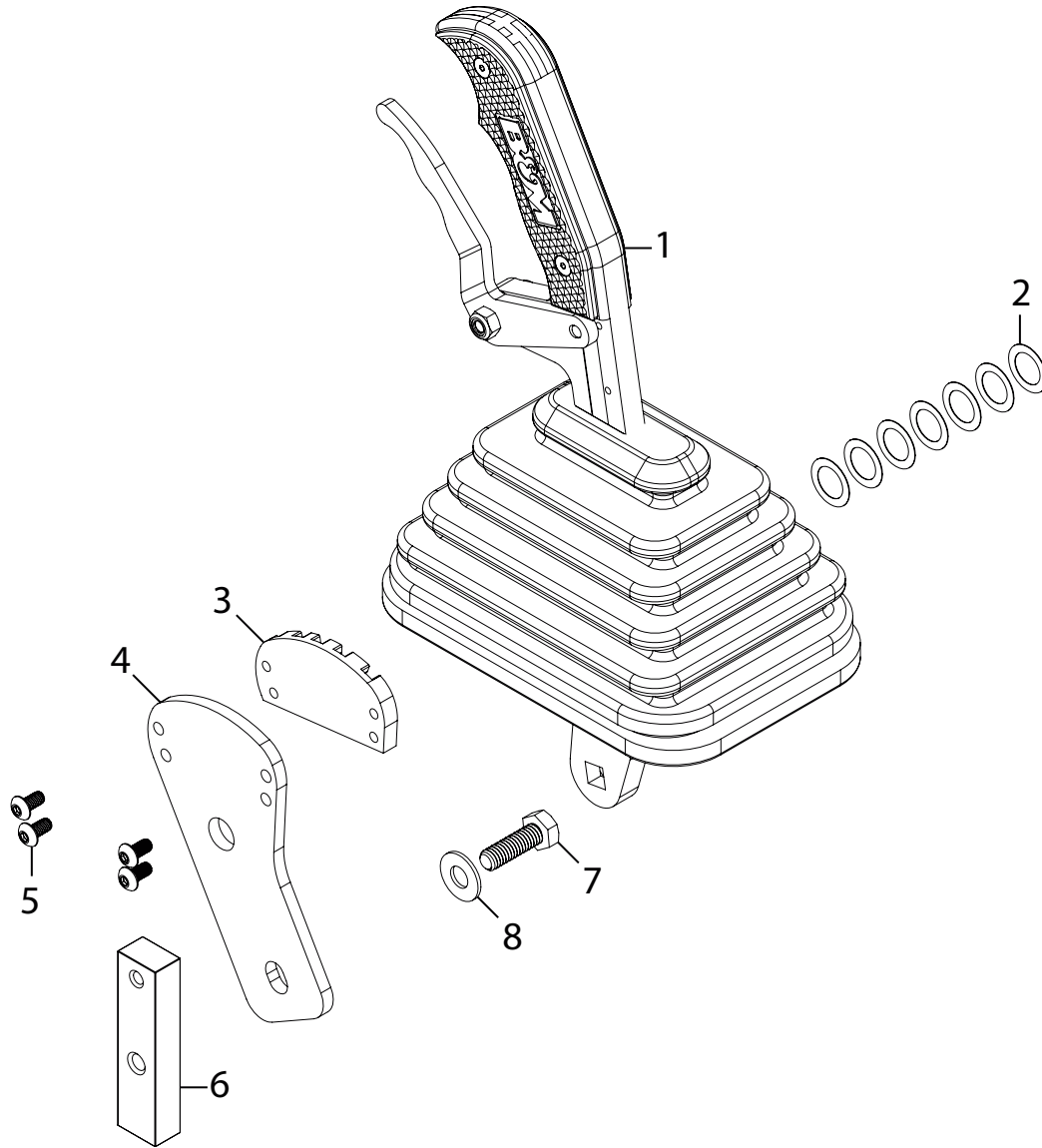

Installation Instructions
81174
MAGNUM GRIP DUAL-GATE
SHIFTER
2014-20 POLARIS RZR XP



ITEM	PART NO.	DESCRIPTION	QTY.	ITEM	PART NO.	DESCRIPTION	QTY.
1	4001787	Stick assembly includes:	1	N/A	3401537	6-32 x 5/16" Screw	4
N/A	4001788	Lever	1	N/A	4001739	Shift Boot	1
	4001789	Selector Pin	1	N/A	81174BA	Hardware Pack includes:	1
	4001790	Pivot Sleeve	1	2	3401626	.01" x 1/2" ID x 3/4" OD Shim	7
	3401622	Curved Disc Spring	1	3	4001794	Gate Plate	1
	3401625	Compression Spring	1	4	4001791	Gate Mount	1
	3401614	8 x 12mm L Shoulder Screw	1	5	3401397	10-32 x 3/8" Screw	4
	3401616	M6-1.0 Nylon Insert Lock Nut	1	6	4001798	Backer Bar	1
	4001492	Left Grip Shifter Plate	1	7	3401624	5/16"-18 x 1" Hex Head Screw	1
	4001495	Right Grip Shifter Plate	1	8	3401562	5/16" Flat Washer	1

OVERVIEW:



1. Take a moment to read and understand these instructions before installing your Flowmaster performance system.

NOTE: Please inventory all parts now before continuing and if necessary, report any missing items to our tech line. This will avoid potentially stranding your vehicle until any missing replacement parts arrive.

REMOVE STOCK COMPONENTS:



2. Securely chock vehicle's wheels to keep it from rolling while shift lever is being manipulated.



3. Remove seats from vehicle to allow for removal of center console.



4. Shift into NEUTRAL, then remove console fasteners (x7) and retain them for later use.



5. Fit rubber boot into center then lift and remove console cover.



6. Remove and retain shift cable lock nut then disconnect cable from shift lever.



9. Remove and retain bushings (x2) from shift lever.

Install XDR Dual Gate Shifter kit:



7. Lift rubber boot then remove and retain E-clip.



10. Apply loctite to screws (x4) (5) and use them to fasten gate mount (4) to gate plate (3).



8. Remove shift lever from pivot shaft, taking care not to lose nylon bushings in each end of the bore.

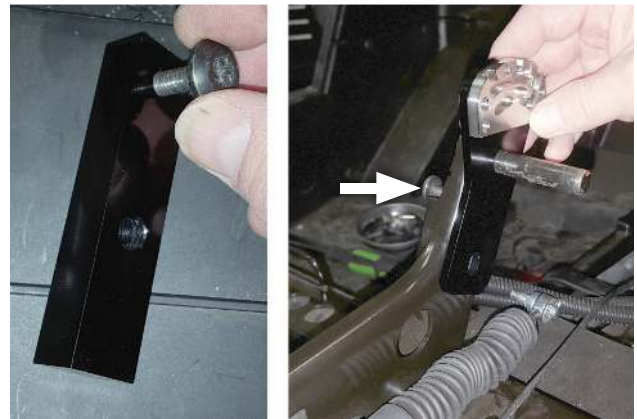

11. Place gate mount assembly onto pivot shaft and set backer bar (6) on other side using a screw to secure it temporarily in place.



12. Apply loctite to **screw (7)** then insert it through **flat washer (8)**, gate mount and backer bar to secure parts together. Hand tighten screw loosely.



13. Assemble bushings (x2) (removed step 9) into both ends of pivot sleeve on **stick (1)**.



14. Place stick onto pivot shaft. Install as many **shims (2)** as necessary onto either side of pivot sleeve until shifter operation is smooth (no drag against gate plate) without too much play. Then secure it in place using e-clip (removed step 7).



15. Now set pin selector into gear shown above.



16. Re-connect shift cable then secure it using shift cable lock nut (removed step 6).



17. Center shifter in gear as shown then finish tightening gate mount to backer bar.



18. Shift through each gear to verify proper function and, if necessary, adjust shifter cable nut for precision.



19. Replace center console (removed step 5).



20. Ensure that all components are pulled completely through console then re-install all fasteners (removed step 4) to secure center console.



21. Re-install driver and passenger seat into vehicle.



Congratulations, the installation of your XDR Dual Gate Shifter kit is now complete!

