

Installation Instructions
615904
TURBO BLOW-OFF /
DIVERTER VALVE
2016-2021 POLARIS RZR XP
 Adjustable pressure release point. Can be setup as a
 blow-off or diverter valve.

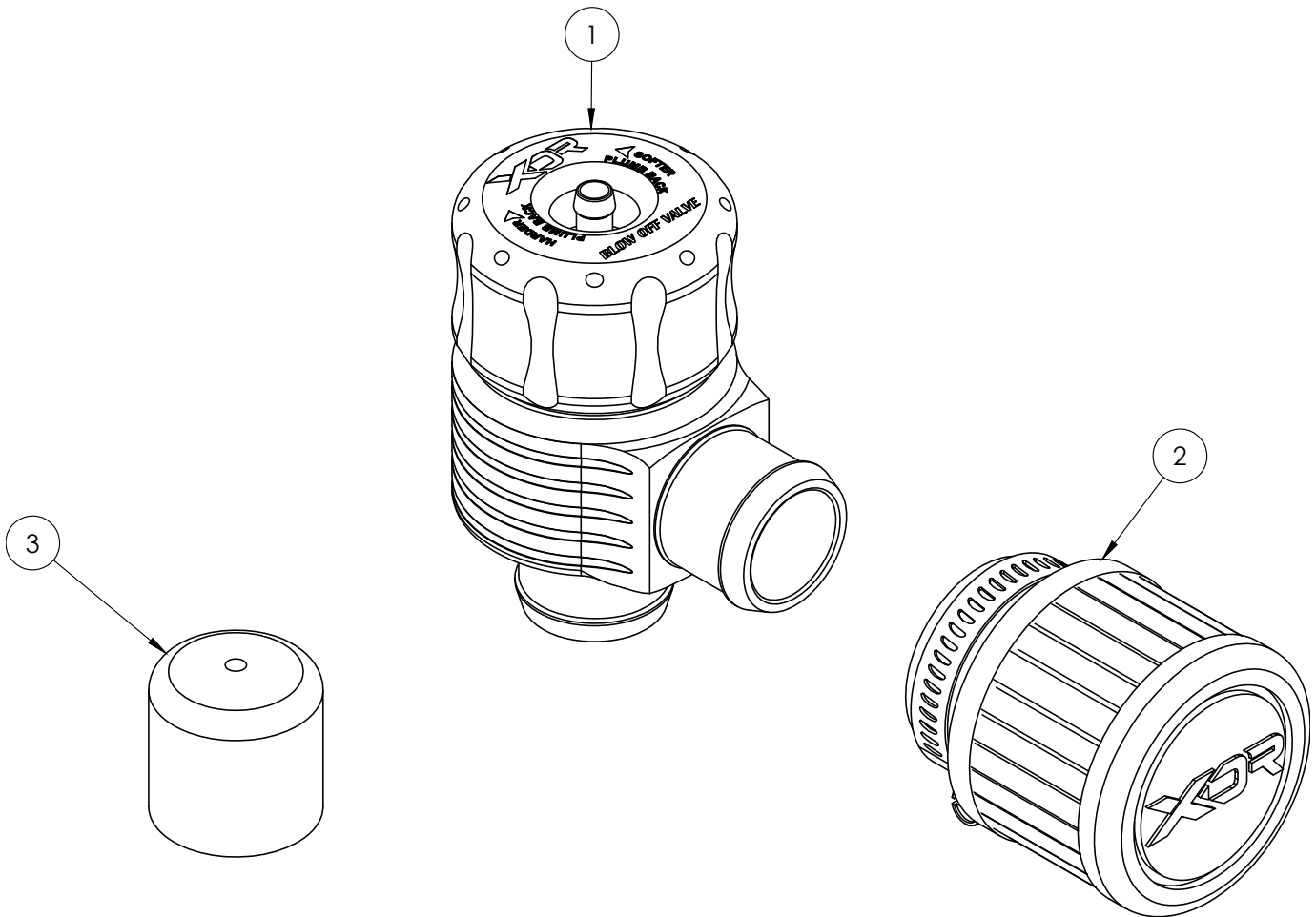

ITEM	PART NO.	DESCRIPTION	QTY.
1	AF8002	25MM Turbo Blow Off Valve, assembly includes:	1
N/A	N/A	Hose Clamp	2
N/A	N/A	Vacuum Hose	2
N/A	N/A	Barb Fitting	2
2	AF1011	Breather Filter	1
3	AF4020	1" Flexible Vinyl Round Cap	1

OVERVIEW:



1. Please take a moment to read and understand these instructions before installing your XDR performance system. Use the parts drawing and list to verify kit contents.

REMOVE FACTORY COMPONENTS:



2. Access factory valve from driver side or through air box compartment.

WARNING:

Avoid serious burns! Allow vehicle time to cool completely before handling any of engine components.



3. Remove clamp securing vacuum tube to valve cap, then detach vacuum tube.



4. Remove clamp then remove valve from charge tube.



5. Loosen clamp securing return to intake tube. Disconnect then remove return tube and valve.

INSTALL XDR TURBO BLOW OFF VALVE:



6. Install **round cap (3)** onto intake tube then secure it using hose clamp.

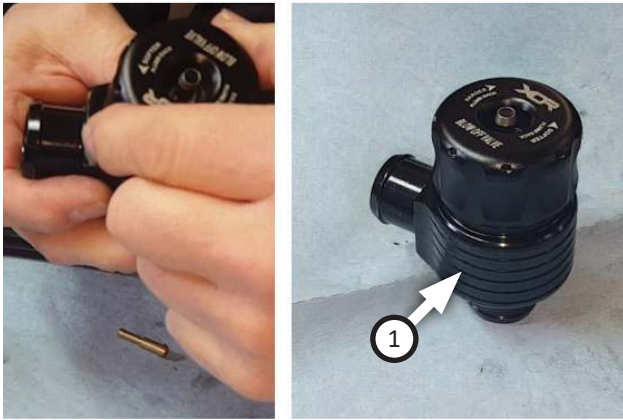

7. Adjust **blow off valve (1)** by hand-tightening fully then loosening 2½ turns. Once installed, valve can be fine tuned according to your preference.

Softer: Allows for a more moderate blow off with a longer duration.

Harder: Creates a more rigid blow off with a shorter duration.

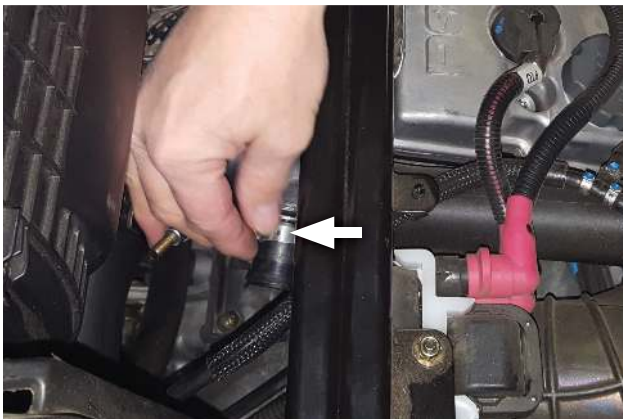

8. Place hose clamp loosely onto charge tube port (from step 4).



9. Place blow off valve onto charge tube port then fit clamp over connection and tighten it just enough to allow for later adjustment.

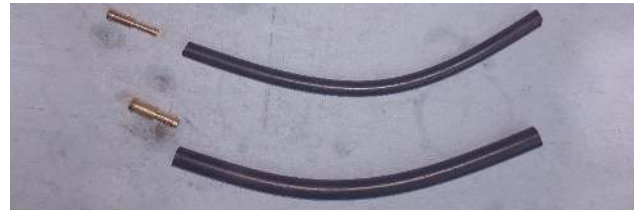

10. Fit barb fitting to vacuum hose. Choose hose size that fits factory vacuum tube (from step 3) on vehicle.

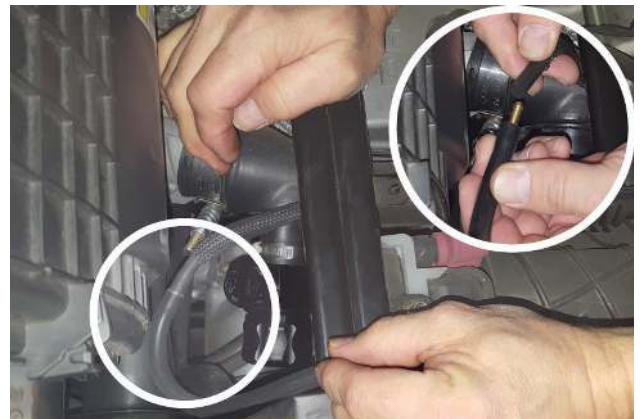

11. Connect vacuum hose assembly to vacuum tube (from step 3).

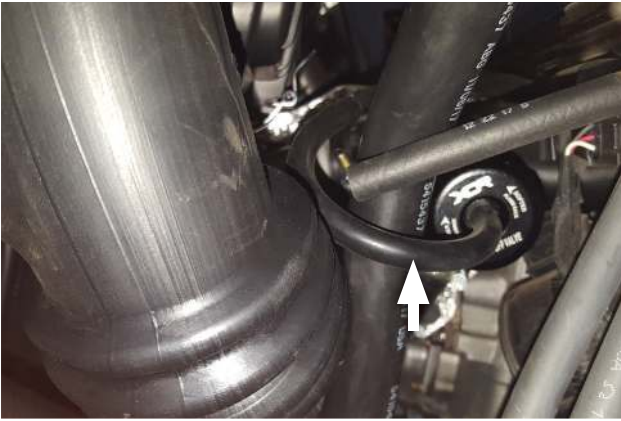

12. Route vacuum hose down around vent tube then connect it to blow off valve.



13. Install **breather filter (2)** onto blow off valve, then tighten it just enough to allow for later adjustment.



14. Adjust components to provide a satisfactory fit. Maintain a minimum of ½" clearance around parts, while allowing for vibration.



15. Plumb-back option: for quieter operation, install blow-off valve as shown leaving out breather filter.

NOTE: Inlet port on factory valve is on its side. Inlet port on XDR valve is on opposite end of vacuum line.



16. Replace cover on air box compartment.

Congratulations, the installation of your performance XDR Turbo Blow Off Valve is now complete!

