

Installation Instructions

Eibach Springs, Inc. • 264 Mariah Circle • Corona, California 92879-1751 • USA • Tech Support 800-222-8811 Ext 114

PRO-UTV #E85-213-001-02-22

Kit Contents	Description	Part Number	Qty
	Front Main Spring	1200.300.0300S	2
	Front Secondary Spring	1000.300.0300S	2
	Rear Main Spring	1600.300.0400S	2
	Rear Secondary Spring	1000.300.0350S	2
	Slider	8001064	4
	Crossover Ring	8001104	8
	Instructions	PRO.UTVINST	1

NOTES: Read All Instructions Before Beginning Installation

- Only qualified technicians experienced in the installation and removal of suspension components should perform this installation.
- Use of a hoist and screw jack is highly recommended and will substantially reduce installation time.
- Never work on or under a vehicle unless it is properly supported.

RECOMMENDED FRONT SET-UP

1. Raise the front of the vehicle and support it with the proper safety equipment. **Note: Never work on or under a vehicle that is not supported by the proper safety equipment.**



Photo 1

2. Remove the cover as this will make it easier to access the upper coilover hardware. (See Photo 1)



Photo 2

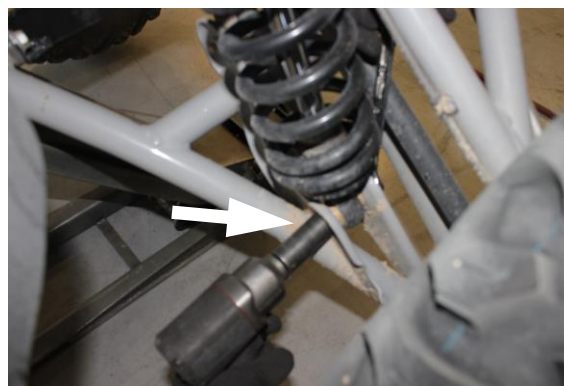

Photo 3



Photo 4

3. Loosen and remove the hardware that secures the coilover to the upper and lower mounts, then, remove the coilover from the vehicle as shown. (See Photos 2, 3 & 4)

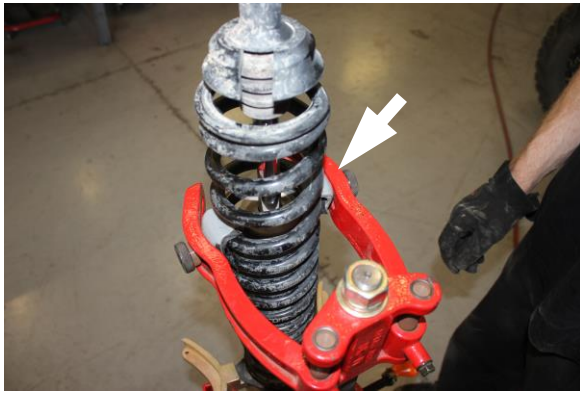

Photo 5



Photo 6

4. Use a spring compressor to compress the spring assembly, then, remove the OE retainer. (See Photos 5 & 6)



Photo 7



Photo 8



Photo 9

5. You can now release the spring compressor and remove the main spring, slider and secondary spring as shown. (See Photos 7, 8 & 9)

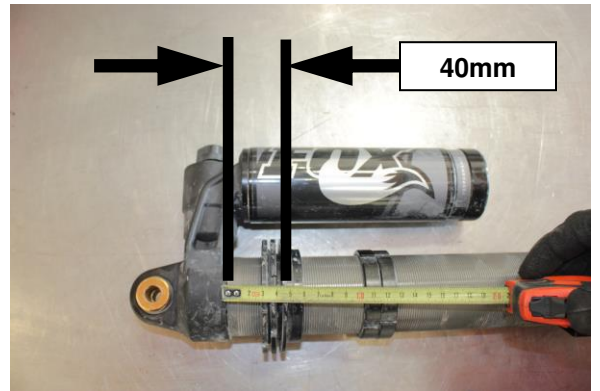

Photo 10

6. Set the preload collar at 40mm as shown. (See Photo 10)

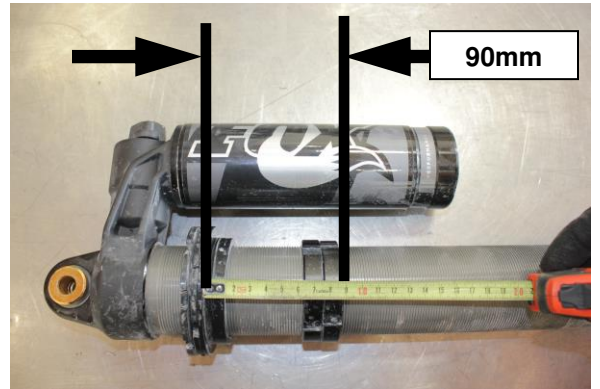

Photo 11

7. Install and set the provided crossover rings to 90mm as shown. (See Photo 11)



Photo 12



Photo 13



Photo 14



Photo 15

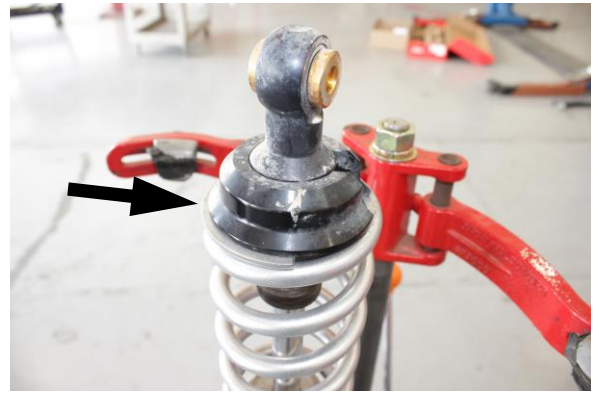

Photo 16

8. You can now install the secondary spring, provided slider, and main spring, then, compress the spring assembly and install the retainer as shown. (See Photos 12, 13, 14, 15 & 16)



Photo 17



Photo 18



Photo 19

9. You can now reinstall the coilover using the factory hardware. (See Photos 17, 18 & 19)
10. Repeat the process on the opposite side, then, set the vehicle on the ground, making sure it's fully settled.

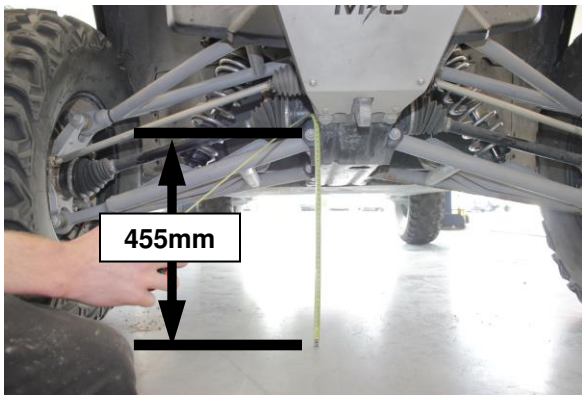

Photo 20

11. You can now adjust the upper preload collar to adjust the ride height. The recommended preload measurement in **Step 6 Photo 10** will get the vehicle close to the recommended ride height but each vehicle may vary some. We recommend setting the ride height at **455mm** measuring from the ground to the center of the lower control arm bolt as shown. **Note: If you have larger than stock wheels and tires, the ride height will be increased.** (See Photo 20)

RECOMMENDED REAR SET-UP

1. Raise the rear of the vehicle until the wheels are off the ground and the suspension is fully unloaded. **Note: Never work on or under a vehicle that is not supported by the proper safety equipment.**



Photo 21

2. Remove the rear wheel as this will make it easier to remove the lower coilover hardware. (See Photo 21)



Photo 22



Photo 23



Photo 24

3. Loosen and remove the hardware that secures the upper and lower coilover mounts, then, remove the coilover as shown. (See Photos 22, 23 & 24)



Photo 25



Photo 26

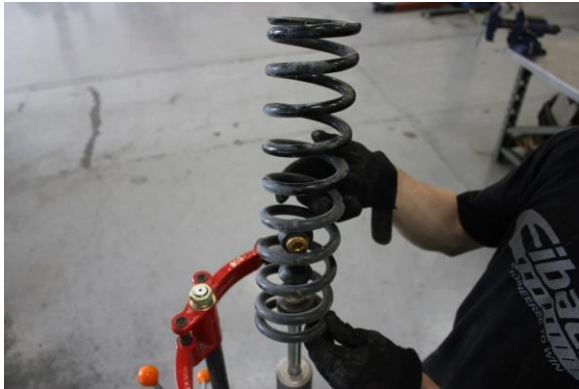

Photo 27



Photo 28



Photo 29

4. Use a spring compressor to compress the spring assembly, then, remove the retainer, main spring, slider and secondary spring as shown. (See Photos 25, 26 27, 28 & 29)

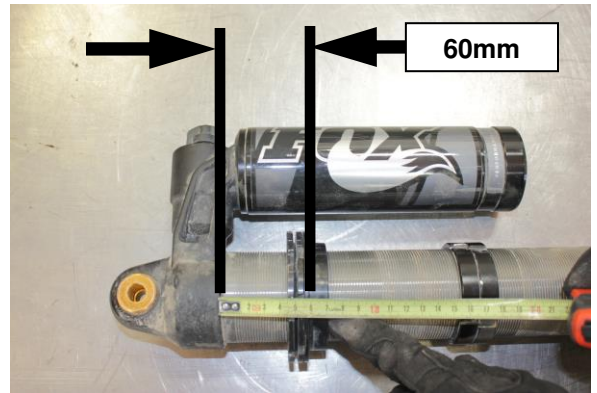

Photo 30

12. Set the preload collar at 60mm as shown. (See Photo 30)

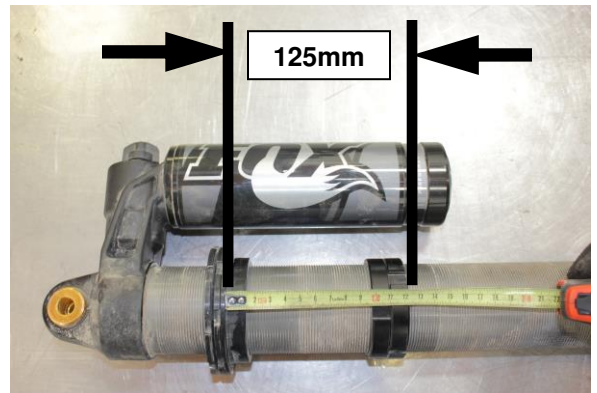

Photo 31

13. Install and set the provided crossover rings to 125mm as shown. (See Photo 31)



Photo 32



Photo 33



Photo 34



Photo 35



Photo 36

5. You can now install the secondary spring, provided slider, and main spring, then, compress the spring assembly and install the retainer as shown. (See Photos 32, 33, 34, 35 & 36)



Photo 37



Photo 38

6. You can now reinstall the coilover and secure it to the upper and lower mounts using the OE hardware. (See Photos 37 & 38)
7. Repeat the process on the opposite side, then, set the vehicle on the ground, making sure it's fully settled.

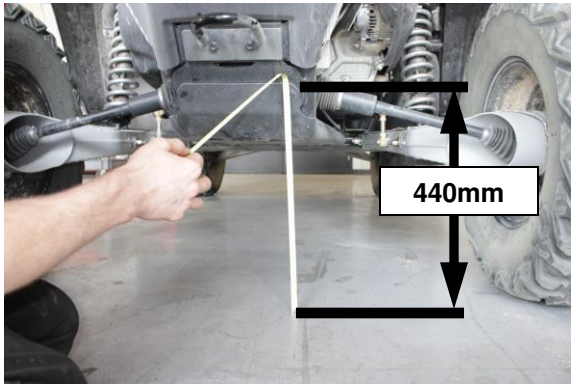

Photo 39

14. You can now adjust the upper preload collar to adjust the ride height. The recommended preload measurement in **Step 12 Photo 30** will get the vehicle close to the recommended ride height but each vehicle may vary some. We recommend setting the ride height at **440mm** measuring from the ground to the center of the lower control arm bolt as shown. **Note: If you have larger than stock wheels and tires, the ride height will be increased.** (See Photo 39)

RECOMMENDED FRONT AND REAR SHOCK SETTINGS

- **Front:** Set at #2 (3 Position Compression)
- **Rear:** Set at #2 (3 Position Compression)

Note: These are the recommended shock settings that we tested using the spring rates provided in this kit.