



**Made for first. Built to last.**

DISCLAIMER:  
PRODUCTS MADE BY L AND W FAB AND MACHINE INC. ARE INTENDED TO FIT YOUR STOCK UTV UNLESS OTHERWISE SPECIFIED. INSTALLING, MODIFYING, OR REMOVING ANY COMPONENTS (FACTORY OR AFTERMARKET) NOT SUPPORTED BY L AND W AND THE INSTRUCTIONS HEREIN WILL VOID YOUR WARRANTY. FOR MORE INFORMATION ON INSTALLATION, WARRANTY, OR PRODUCT USE PLEASE CALL US AT (770) 445-9778

## CAN AM X3 72" RADIUS RODS

Fitment: 2017-2022 CAN AM MAVERICK X3 72" (ALL TRIMS)



INSTALLATION MANUAL

# Parts List:

Item #	Description	Qty.
1	UPPER RADIUS ROD W/ HEIMS	2
2	LOWER RADIUS ROD	2
3	TOE LINK ROD	2
4	UNIBALL MISALIGNMENT SPACER	16
5	HEIM MISALIGNMENT SPACER	8

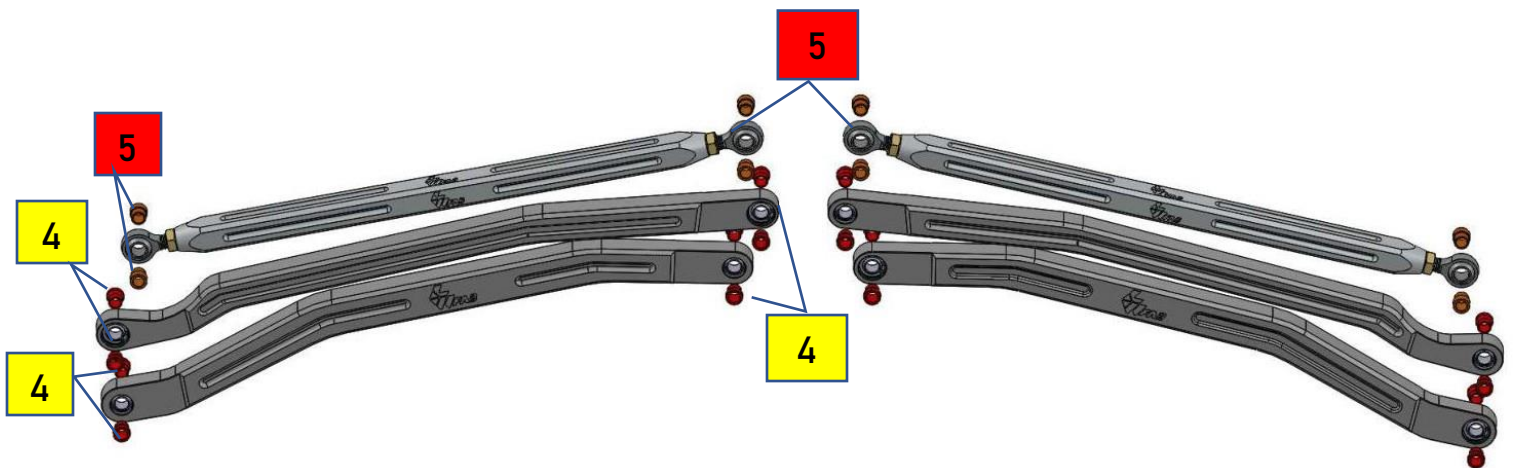
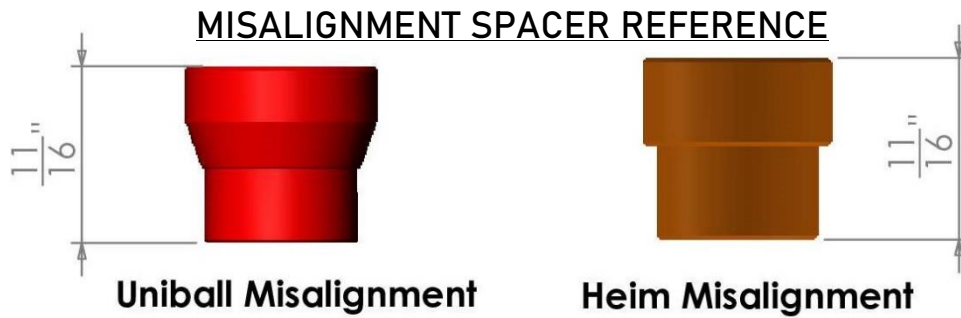

# Installation:

## STEP 1:

Jack machine up and remove wheels.

## STEP 2:

Using a 18mm socket and wrench, remove the 6 factory radius rod bolts On wheel side, and the 6 nuts at the radius rod plate. Remove old radius rods and prepare to install your new L&W Rods.

Overlay or measure upper rods with the new adjustable uppers. If your factory rod is bent, start at adjusting the rods to 26-11/16" from center of heim to center of Heim.

## STEP 3:

Install the supplied misalignment bushings into your new arms. Refer to Figure 1 below for placement of Misalignment bushings.

Figure 1

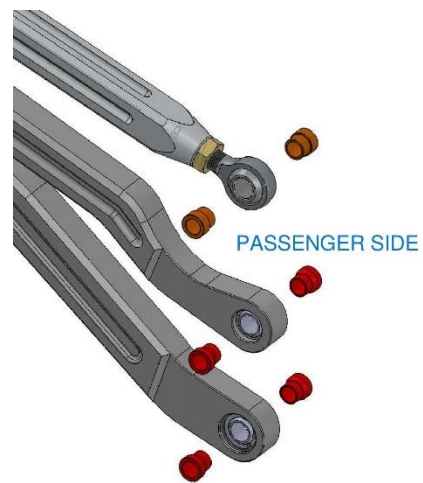
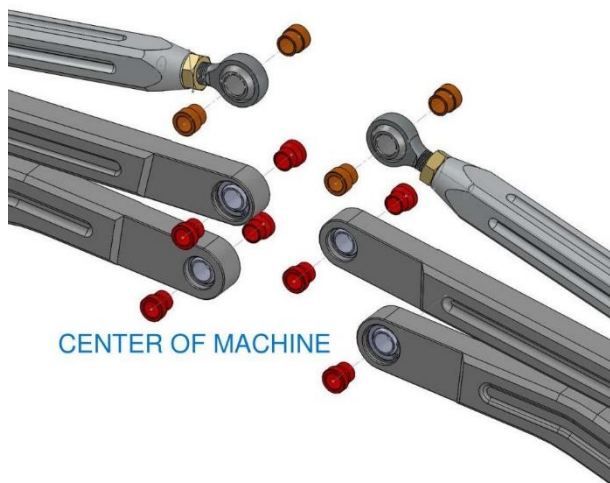

#### STEP 4:

With the misalignments in place, install the rods back on machine using the factory bolts you removed in step 1. The bushings are designed to be a very snug fit. A dead blow hammer and line up bar will help with persuading the arms into place.



#### STEP 5:

With everything in place, Reinstall center radius rod plate. Torque all bolts to 80 ft/lb.

#### STEP 6:

Reinstall wheels. Be sure to drive the machine around to let the suspension settle. After suspension is settled, Adjust camber with upper rod until satisfied.



**THANK YOU FOR CHOOSING L&W FAB!**