



MADE FOR FIRST. BUILT TO LAST.

DISCLAIMER:

PRODUCTS MADE BY L AND W FAB AND MACHINE INC. ARE INTENDED TO FIT YOUR STOCK UTV UNLESS OTHERWISE SPECIFIED. INSTALLING, MODIFYING, OR REMOVING ANY COMPONENTS (FACTORY OR AFTERMARKET) NOT SUPPORTED BY L AND W AND THE INSTRUCTIONS HEREIN WILL VOID YOUR WARRANTY. FOR MORE INFORMATION ON INSTALLATION, WARRANTY, OR PRODUCT USE PLEASE CALL US AT (770) 445-9778

2019 POLARIS RZR WINCH MOUNT

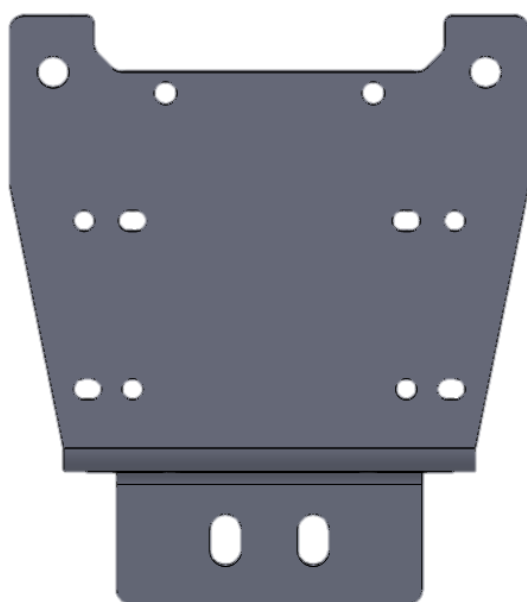

INSTALLATION MANUAL

PARTS LIST:

Item #	Part #	Description	Qty.
1	N/A	Winch Mount	1
2	N/A	Winch Mount Cover (Only When Required)	1
3	N/A	Upper Angle Support	1
4	N/A	Lower Support	1
5	95462A032	7/16 Welded Nut Plate	2
6	92620A673	7/16 x 1 1/4 Bolt	2
7	91102A765	7/16 Lock Washer	4
8	92620A626	3/8 x 1 1/4 Bolt	2
9	92620A671	7/16 x 1 1/4 Bolt	2
10	94895A031	3/8 Nut	2
11	94895A817	7/16 Nut	2
12	91104A031	3/8 Lock Washer	2
13	90126A032	7/16 Lock Washer	2
14	92620A712	1/2 x 1 Bolt	2
15	94895A823	1/2 Nut	2
16	91102A770	1/2 Lock Washer	2

Front:

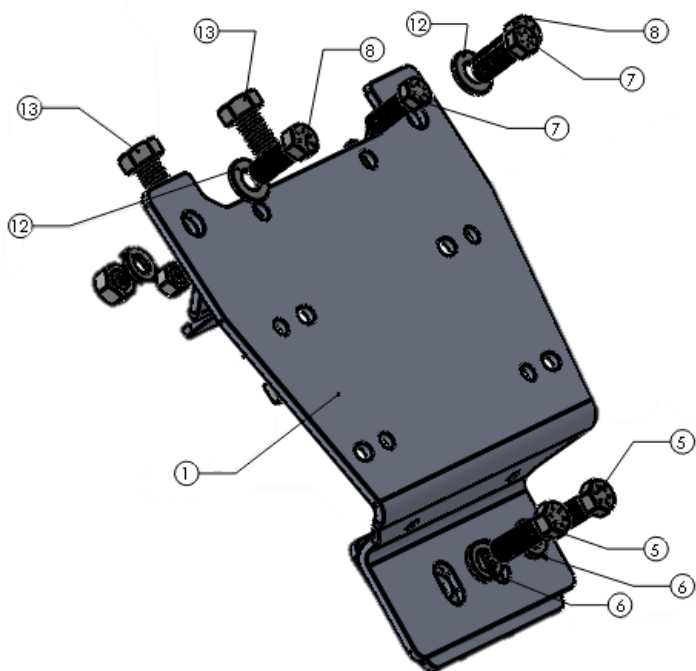

Back:

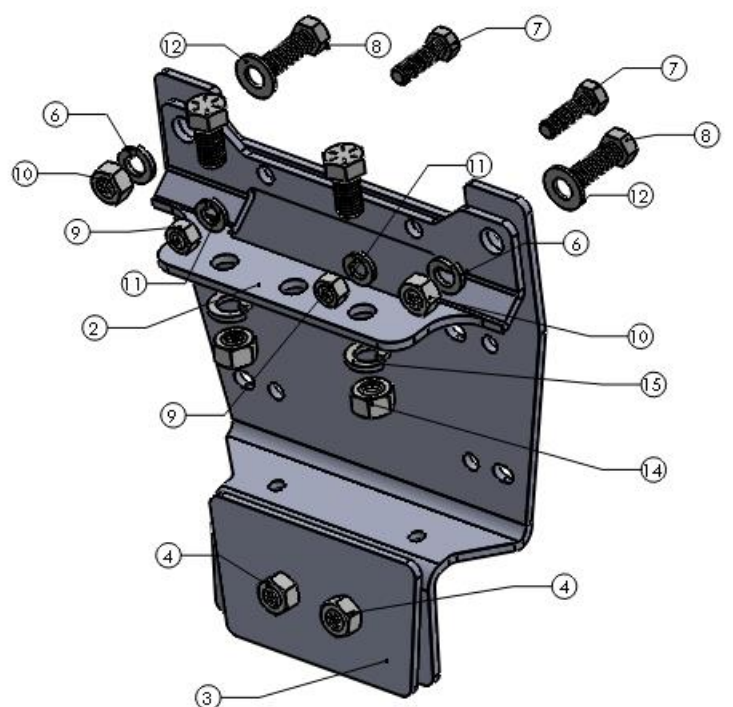

INSTALLATION:

STEP 1: Lay out the supplied parts and hardware as shown in *figure 1* below. Remove the grill, plastic cover below it, and pull hook if it is installed on your vehicle. Your vehicle should resemble *figure 2* when you are ready to continue.

Figure 1

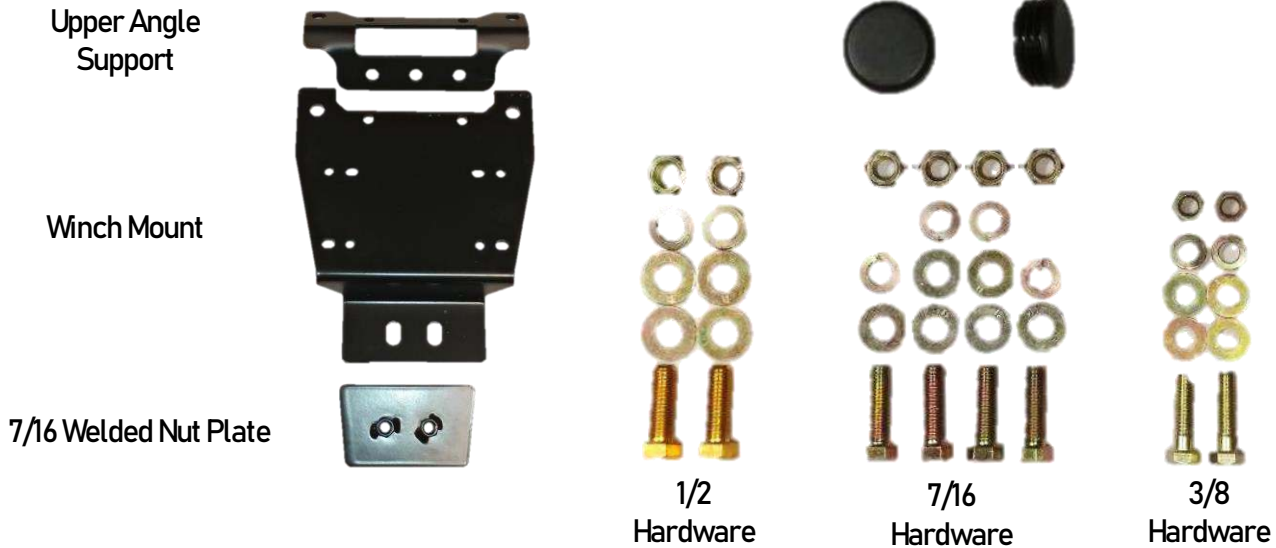

Figure 2



STEP 2: Mount the winch onto the Winch Plate using the hardware supplied with it. The correct orientation of the plate would leave the bent leg going away from the body of the winch and when mounted toward the back of the machine. Use *figure 3* to verify the fitment of the Winch Plate.

Figure 3



STEP 3: Insert the Upper Support Bracket in front of the radiator between the frame rails. Center the bracket on the line of holes across the frame and use the supplied $\frac{1}{2}$ hardware on the outside holes to secure the bracket. A small slot can be utilized to put on the lock washers and nuts. Use *figure 4* and *5* for reference.

NOTE: ONLY START THE NUTS. DO NOT TIGHTEN THEM COMPLETELY UNTIL THE END OF ASSEMBLY.

Figure 4



Figure 5



STEP 4: Place the Winch Mount Assembly behind the plastic and line up the four bolt holes on the mounting plate to the holes on the upper support bracket. Use the two of the supplied $\frac{3}{8}$ bolts in the center holes to secure the winch mount assembly as shown in *figure 6*. Start the bolts with the included washers and lock washers.

NOTE: ONLY START THE NUTS. DO NOT TIGHTEN THEM COMPLETELY UNTIL THE END OF ASSEMBLY.

Figure 6



STEP 5: Use two of the provided 7/16 hardware to secure the bumper to the two top holes of the winch plate as shown in *figure 7*. Next, use two of the provided 7/16 bolts to secure the bottom of the bumper to the provided 7/16 Welded Nut Plate. The plate may have to be held in place from behind while starting each bolt. In addition, you will likely have to lift and/or maneuver the winch or bumper to line up the holes. Use *figures 7, 8, and 9* for assembly reference.

Figure 7



Figure 8

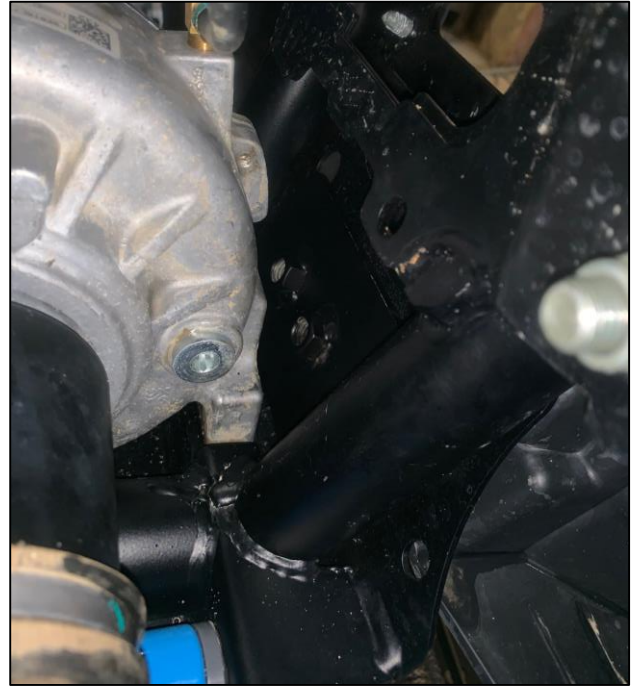

Figure 9



STEP 6: With all bolts started and everything finally in place, start tightening in the following order:

1/2" bolts in upper support. It is tight, but using a wrench, you can go above the front differential from behind and reach the nuts on bottom.

7/16" and 3/8" bolts on the top

Lastly, tighten the 7/16 bolts on bottom.

Review the components and ensure all hardware is tightened down and secure.



TEMPLE, GA 30179



(770) 445-9778

THANK YOU FOR CHOOSING L&W FAB AND MACHINE INC!