



**Made for first. Built to last.**

DISCLAIMER:  
PRODUCTS MADE BY L AND W FAB AND MACHINE INC. ARE INTENDED TO FIT YOUR STOCK UTV UNLESS OTHERWISE SPECIFIED. INSTALLING, MODIFYING, OR REMOVING ANY COMPONENTS (FACTORY OR AFTERMARKET) NOT SUPPORTED BY L AND W AND THE INSTRUCTIONS HEREIN WILL VOID YOUR WARRANTY. FOR MORE INFORMATION ON INSTALLATION, WARRANTY, OR PRODUCT USE PLEASE CALL US AT (770) 445-9778

## **Polaris RZR 1 HEIM UPPER Radius Rods**

Fitment: 2017.5-CURRENT RZR XP/XPT/RS1



**INSTALLATION MANUAL**

# Parts List:

Item #	Description	Qty.
1	UPPER RADIUS ROD	2
2	LOWER RADIUS ROD	2
3	HEIM MISALIGNMENT	4
4	THIN MISALIGNMENT	4
5	MEDIUM MISALIGNMENT	4
6	THICK MISALIGNMENT	4
7	RUBBER O RING	8

## MISALIGNMENT BUSHING REFERENCE

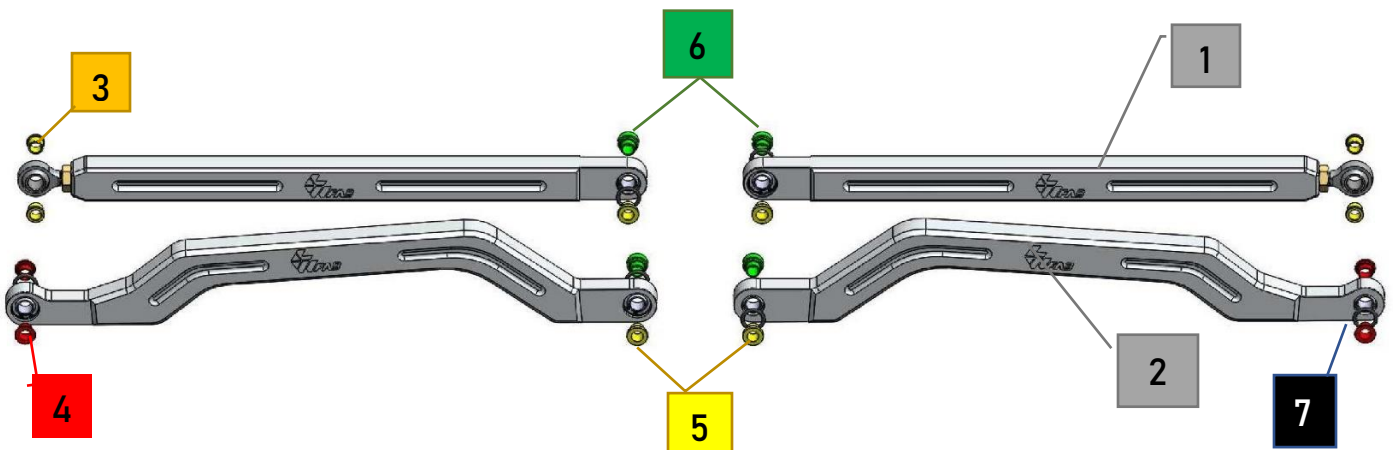
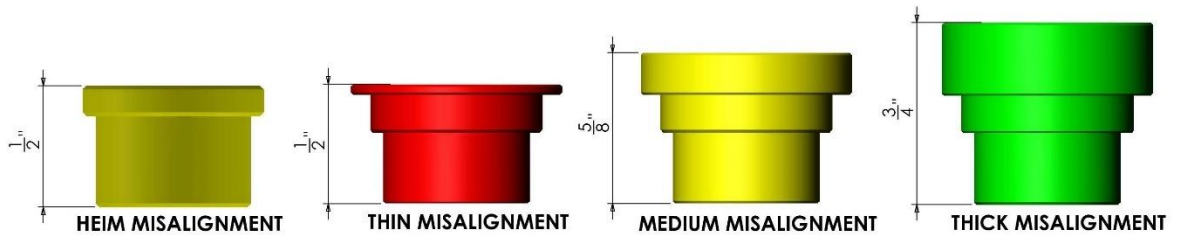

# Installation:

## STEP 1:

Jack machine up and remove wheels.

## STEP 2:

Using a 18mm OR 15mm socket and wrench, remove the 8 factory radius rod bolts. Remove old radius rods and prepare to install your new L&W Rods.

## STEP 3:

Install the supplied misalignment bushings and O-rings into your new arms. Refer to Figure 1 below for placement of Misalignment bushings and O-rings. The thin bushings will go to the wheel side. The thick bushing will go on the back side at the frame end, and the medium bushing on the front side at the frame end. The reason for the different thickness is for spacing radius rods at the needed clearance away from the frame.

**NOTE: Install O-ring on the side OPPOSITE of snap ring. Install O-ring into hole first, then insert misalignment.**

- A good place to start is screw heim out to a measurement of 24-5/16" center of hole to center of hole

Figure 1

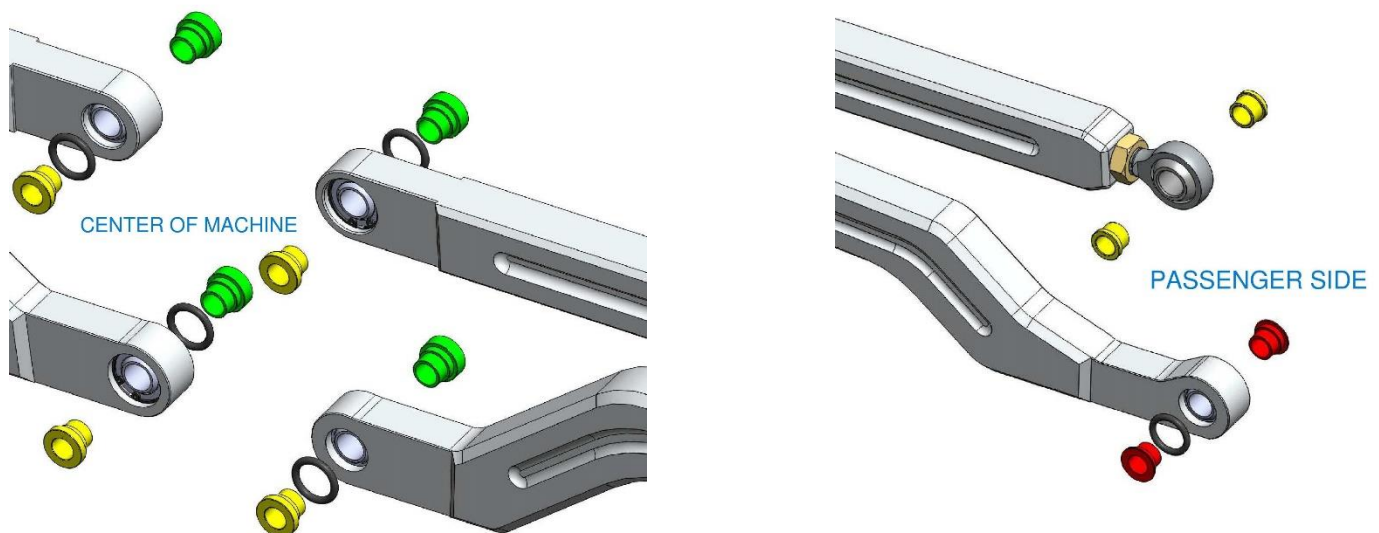

## STEP 3:

With the misalignments and o-rings in place, install the rods back on machine using the factory bolts you removed in step 1. The bushings are designed to be a very snug fit. A dead blow hammer and line up bar will help with persuading the arms into place.

**STEP 4:**

With everything in place, and bolts started, torque all bolts to 80 ft/lb.

**STEP 5:**

Reinstall wheels. Be sure to drive the machine around to let the suspension settle. After settling the suspension, check wheel camber, and adjust heim to achieve desired camber.



**THANK YOU FOR CHOOSING L&W FAB!**