



Made for first. Built to last.

DISCLAIMER:

PRODUCTS MADE BY L AND W FAB AND MACHINE INC. ARE INTENDED TO FIT YOUR STOCK UTV UNLESS OTHERWISE SPECIFIED. INSTALLING, MODIFYING, OR REMOVING ANY COMPONENTS (FACTORY OR AFTERMARKET) NOT SUPPORTED BY L AND W AND THE INSTRUCTIONS HEREIN WILL VOID YOUR WARRANTY. FOR MORE INFORMATION ON INSTALLATION, WARRANTY, OR PRODUCT USE PLEASE CALL US AT (770) 445-9778

Polaris RZR TURBO S DB RADIUS RODS

Fitment: 2018-CURRENT RZR Turbo S



INSTALLATION MANUAL

Parts List:

Item #	Description	Qty.
1	UPPER RADIUS ROD	2
2	LOWER RADIUS ROD	2
3	MISALIGNMENT SPACER	16
4	RUBBER O RING	8

MISALIGNMENT SPACER REFERENCE

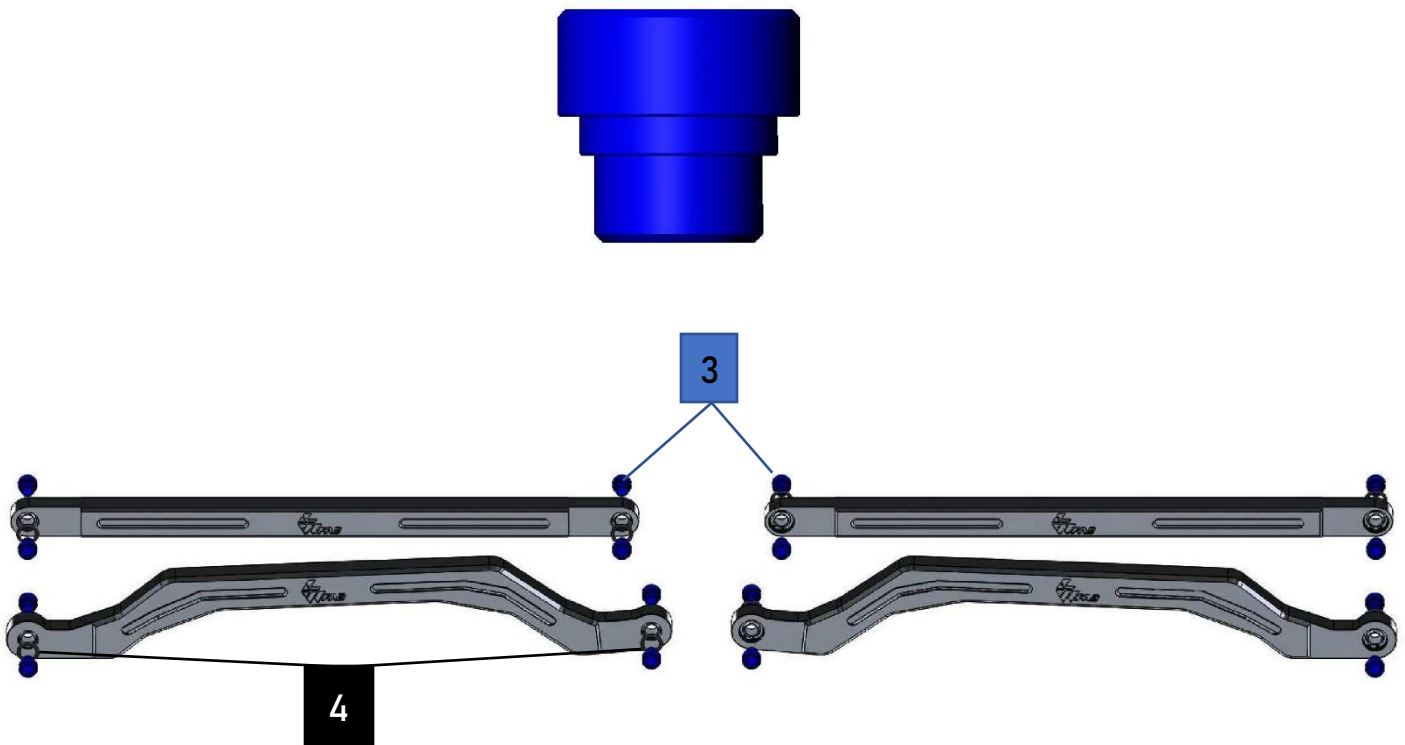

Installation:

STEP 1:

Jack machine up and remove wheels.

STEP 2:

Using a 18mm socket and wrench, remove the 8 factory radius rod bolts. Remove old radius rods and prepare to install your new L&W Rods.

STEP 3:

Install the supplied misalignment bushings and O-rings into your new arms. Refer to Figure 1 below for placement of Misalignment bushings and O-rings. The O-rings go on the side **OPPOSITE** of the snap ring on all rods.

IMPORTANT: INTALL O-RING INTO HOLE FIRST, THEN PRESS MISALIGNMENT INTO HOLE.

Figure 1

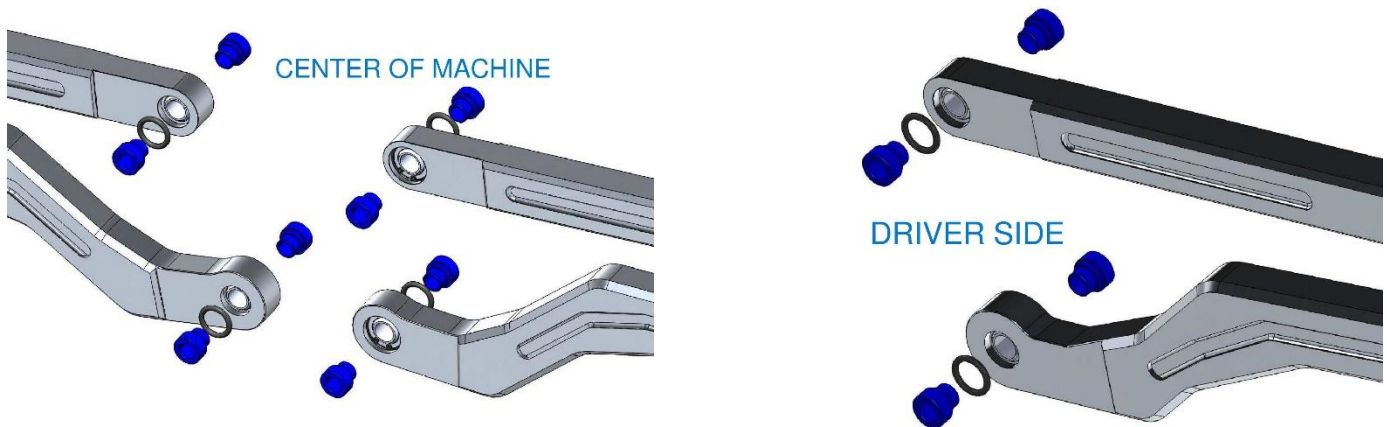

STEP 3:

With the misalignments and o-rings in place, install the rods back on machine using the factory bolts you removed in step 1. The bushings are designed to be a very snug fit. A dead blow hammer and line up bar will help with persuading the arms into place.

STEP 4:

With everything in place, and bolts started, torque all bolts to 80 ft/lb.

STEP 5:

Reinstall wheels. Be sure to drive the machine around to let the suspension settle.



THANK YOU FOR CHOOSING L&W FAB!